

OWNERS GUIDE TO INSTALLATION AND OPERATION

4" — 35-85 GPM and 6" — 50-250 GPM 8" — 325-400 GPM SUBMERSIBLE PUMPS

WARNING IMPORTANT SAFETY INSTRUCTIONS RULES FOR SAFE INSTALLATION AND OPERATION

1. Read these warnings and instructions carefully. Failure to follow them could cause serious bodily injury and/or property damage.
 2. Follow all local electrical and safety codes as well as the National Electrical Code (NEC) and the Occupational Safety and Health Act (OSHA).
 3. The power supply should be a separate circuit, independent of all other circuits. Be sure it is equipped with a fuse and disconnect box of ample capacity.
 4. For fire protection, the power supply should be free of any building, preferably on a direct line from the transformer. In the event of fire, the wires will not be destroyed and the water supply not cut-off.
 5. **Always** disconnect power source before performing any work on or near the motor or its connected load. If the power disconnect point is out-of-sight, lock it in the open position and tag it to prevent unexpected application of power. Failure to do so could result in fatal electrical shock.
 6. **DO NOT** handle pump with wet hands or when standing in water as fatal electrical shock could occur. Disconnect main power supply before handling pump for any reason.
 7. Shut off power source when voltage drops 10% below the rated voltage of the motor.
 8. Protect the power cable from coming in contact with sharp objects, oil, grease, hot surfaces or chemicals. **DO NOT** kink the power cable. If damaged replace immediately.
 9. **NEVER** leave the control box, fused disconnect switch, or covers open (either partially or completely) when not being worked on by a competent electrician or repairman.
 10. Always use caution when operating electrical controls in damp areas. If possible, avoid all contact with electrical equipment during thunderstorms or extreme damp conditions.
 11. Install all electrical equipment in protected area to prevent mechanical damage which could produce serious electrical shock and/or equipment failure.
 12. Pump is designed to pump cold ground water that is free of air or gases. Decreased pump performance and life expectancy can occur if the ground water is not cold (86F/30C) or contains air or gases.
 13. Pump and controls must be securely and adequately grounded as specified in section 250-43 item (A) of the U.S.A. National Electric Code (NEC) and Section 26-954 Canadian Electrical Code. Failure to do so could result in a fatal injury.
 14. **DO NOT** use this pump to pump flammable liquids such as gasoline, fuel oil, kerosene, etc. Failure to follow the above warning could result in property damage and/or personal injury.
- WARNING: The pump is intended for use in a well. Motor frame must be connected to power supply ground or fatal electrical shock may result. Do not use this pump in swimming pools.**
- NOTE: Pumps with the "CSA" mark are tested to UL standard UL778 and certified to CSA standard C22.2 No. 108.

130582 C

Typical Installation

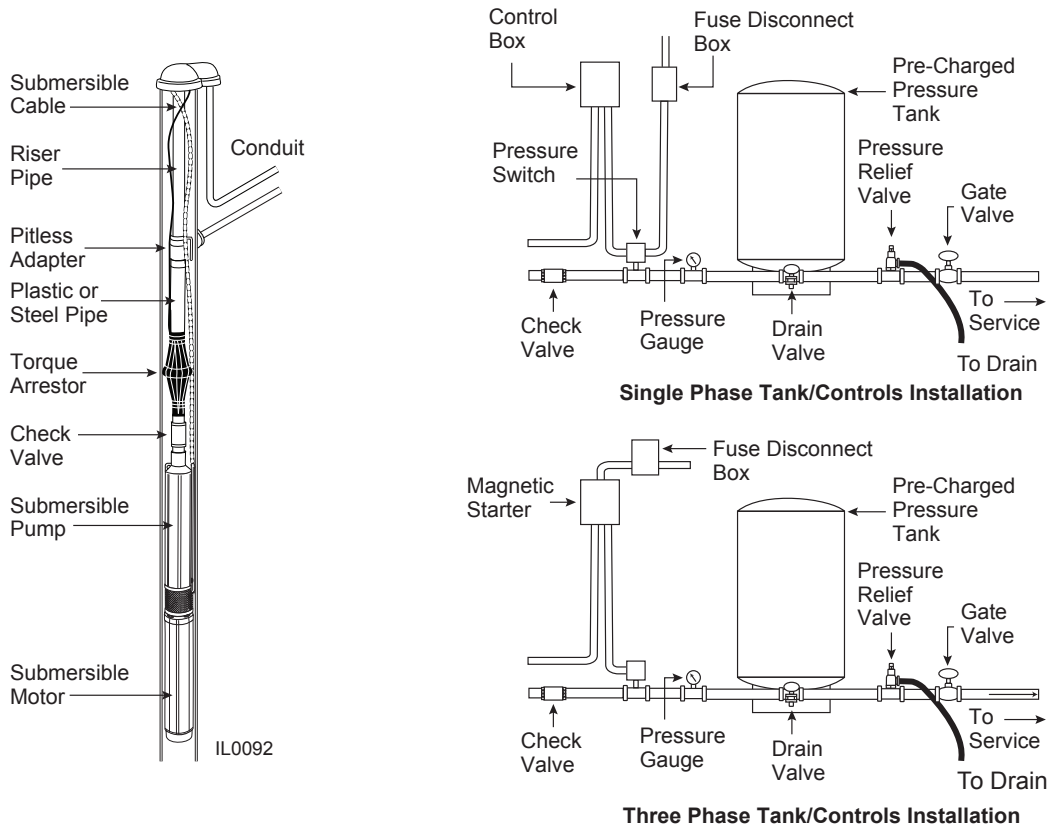
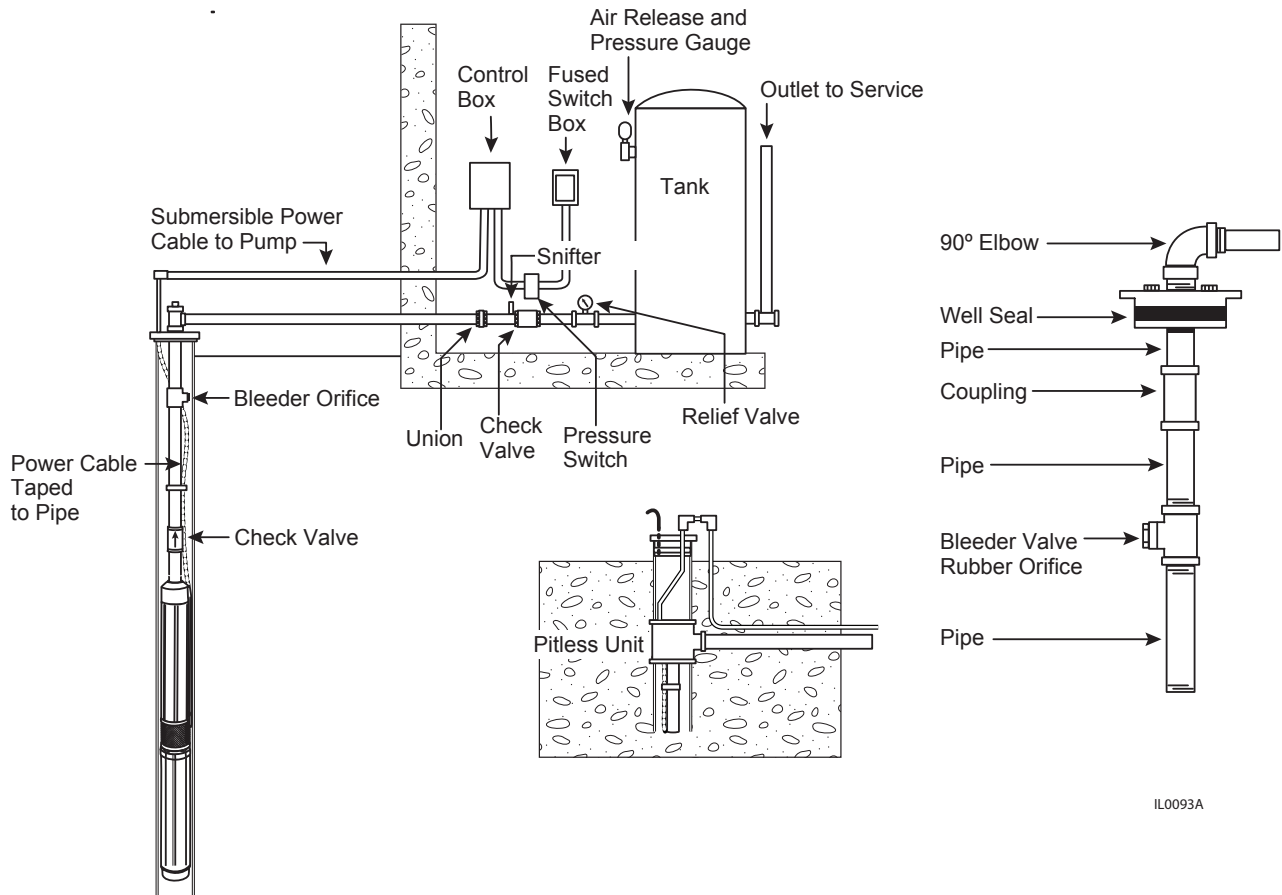

Figure 1 — Typical Installation with Pre-Charged Tank



IL0093A

Figure 2 — Typical Installation with Standard Pneumatic Tank

CABLE SELECTION

Single Phase, 2-Wire or 3-Wire Cable, 60 Hz (Service Entrance to Motor)														
Motor Rating		Copper Wire Size												
Volts	HP	14	12	10	8	6	4	3	2	1	0	00	000	0000
115	1/3	130	210	340	540	840	1300	1610	1960	2390	2910	3540	4210	5060
	1/2	100	160	250	390	620	960	1190	1460	1780	2160	2630	3140	3770
230	1/3	550	880	1390	2190	3400	5250	6520	7960	9690	11770			
	1/2	400	650	1020	1610	2510	3880	4810	5880	7170	8720			
	3/4	300	480	760	1200	1870	2890	3580	4370	5330	6470	7870		
	1	250	400	630	990	1540	2380	2960	3610	4410	5360	6520		
	1-1/2	190	310	480	770	1200	1870	2320	2850	3500	4280	5240		
	2	150	250	390	620	970	1530	1910	2360	2930	3620	4480		
	3	120*	190	300	470	750	1190	1490	1850	2320	2890	3610		
	5	0	0	180*	280	450	710	890	1110	1390	1740	2170	2680	
	7-1/2	0	0	0	200*	310	490	610	750	930	1140	1410	1720	
	10	0	0	0	0	250	390	490	600	750	930	1160	1430	1760
	15	0	0	0	0	170*	270*	340	430	530	660	820	1020	1260

1 foot = .3048 meters

Three Phase, 3-Wire, 60 Hz, 200 and 230 Volts (Service Entrance to Motor)																			
Motor Rating		Copper Wire Size																	
Volts	HP	14	12	10	8	6	4	3	2	1	0	00	000	0000	250	300	350	400	500
200V 60Hz 3 Phase 3 Wire	1/2	710	1140	1800	2840	4420													
	3/4	510	810	1280	2030	3160													
	1	430	690	1080	1710	2670	4140	5140											
	1-1/2	310	500	790	1260	1960	3050	3780											
	2	240	390	610	970	1520	2360	2940	3610	4430	5420								
	3	180	290	470	740	1160	1810	2250	2760	3390	4130								
	5	110*	170	280	440	690	1080	1350	1660	2040	2490	3050	3670	4440	5030				
	7-1/2	0	0	200	310	490	770	960	1180	1450	1770	2170	2600	3150	3560				
	10	0	0	0	230*	370	570	720	880	1090	1330	1640	1970	2390	2720	3100	3480	3800	4420
	15	0	0	0	160*	250*	390	490	600	740	910	1110	1340	1630	1850	2100	2350	2570	2980
	20	0	0	0	0	190*	300*	380	460	570	700	860	1050	1270	1440	1650	1850	2020	2360
25	0	0	0	0	0	240*	300*	370*	460	570	700	840	1030	1170	1330	1500	1640	1900	
30	0	0	0	0	0	0	250*	310*	380*	470	580	700	850	970	1110	1250	1360	1590	
230V 60Hz 3 Phase 3 Wire	1/2	930	1490	2350	3700	5760	8910												
	3/4	670	1080	1700	2580	4190	6490	8060	9860										
	1	560	910	1430	2260	3520	5460	6780	8290										
	1-1/2	420	670	1060	1670	2610	4050	5030	6160	7530	9170								
	2	320	510	810	1280	2010	3130	3890	4770	5860	7170	8780							
	3	240	390	620	990	1540	2400	2980	3660	4480	5470	6690	8020	9680					
	5	140*	230	370	590	920	1430	1790	2190	2690	3290	4030	4850	5870	6650	7560	8460	9220	
	7-1/2	0	160*	260	420	650	1020	1270	1560	1920	2340	2870	3440	4160	4710	5340	5970	6500	7510
	10	0	0	190*	310	490	760	950	1170	1440	1760	2160	2610	3160	3590	4100	4600	5020	5840
	15	0	0	0	210*	330	520	650	800	980	1200	1470	1780	2150	2440	2780	3110	3400	3940
	20	0	0	0	0	250*	400	500	610	760	930	1140	1380	1680	1910	2180	2450	2680	3120
25	0	0	0	0	0	320*	400	500	610	750	920	1120	1360	1540	1760	1980	2160	2520	
30	0	0	0	0	0	260*	330*	410*	510	620	760	930	1130	1280	1470	1650	1800	2110	
460V 60 Hz 3 Phase 3 Wire	1/2	3770	6020	9460															
	3/4	2730	4350	6850															
	1	2300	3670	5770	9070														
	1-1/2	1700	2710	4270	6730														
	2	1300	2070	3270	5150	8050													
	3	1000	1600	2520	3970	6200													
	5	590	950	1500	2360	3700	5750												
	7-1/2	420	680	1070	1690	2640	4100	5100	6260	7680									
	10	310	500	790	1250	1960	3050	3800	4680	5750	7050								
	15	0	340*	540	850	1340	2090	2600	3200	3930	4810	5900	7110						
	20	0	0	410*	650	1030	1610	2000	2470	3040	3730	4580	5530						
25	0	0	0	530*	830	1300	1620	1990	2450	3010	3700	4470	5430						
30	0	0	0	430*	680	1070	1330	1640	2030	2490	3060	3700	4500	5130	5860				
40	0	0	0	0	500*	790	980	1210	1490	1830	2250	2710	3290	3730	4250				
50	0	0	0	0	0	640*	800	980	1210	1480	1810	2190	2650	3010	3420	3830	4180	4850	
60	0	0	0	0	0	540*	670*	830*	1020	1250	1540	1850	2240	2540	2890	3240	3540	4100	
75	0	0	0	0	0	0	0	680*	840*	1030	1260	1520	1850	2100	2400	2700	2950	3440	
100	0	0	0	0	0	0	0	0	620*	760*	940*	1130	1380	1560	1790	2010	2190	2550	

CAUTION: Use of wire size smaller than listed will void warranty.

(*) Meet the U.S. National Electrical Code ampacity only for individual conductor 60°C cable. Only the lengths without * meet the code for jacketed 60°C cable. Local code requirements may vary.

Maximum lengths shown maintain motor voltage at 95% of service entrance voltage, running at maximum nameplate amperes. If service entrance voltage will be at least motor nameplate voltage under normal load conditions, 50% additional length is permissible for all sizes.

This table is based on copper wire. If aluminum wire is used it must be two (2) sizes larger. Example: When the table calls for #12 copper wire you would use #10 aluminum wire.

Single phase control boxes may be connected at any point of the total cable length.

Cables #14 to #0000 are AWG sizes.

READ THESE INSTRUCTIONS COMPLETELY BEFORE INSTALLATION

ASSEMBLY

CAUTION: Be sure pump size corresponds with horsepower size of motor. If pump size exceeds recommended motor, overloading of motor and damage to the motor could result.

1. If not yet assembled, check that the pump and motor mounting faces are free from dirt.
2. Assemble the pump liquid end and motor together so that mounting faces are in contact. Then tighten assembly bolts evenly.

NOTE: Apply non-toxic FDA approved waterproof grease such as Mobile 102, Texaco CYGNUS2661 or equivalent to the coupling before assembly of pump coupling to motor shaft. This will prolong spline life and prevent abrasives from entering the spline area.

3. Check for free rotation of the pump and motor. A slight drag is permissible.
4. Assemble the pump lead guard over the motor leads.
CAUTION: Do not cut or pinch lead wire during assembly.
5. Assemble suction screen to pump mounting ring.

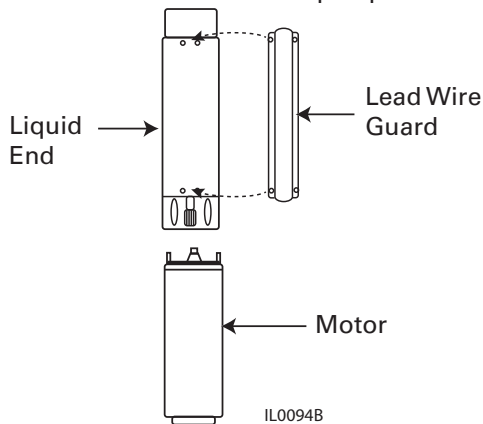

Figure 3

PRE-INSTALLATION

To save possible added expense and extra trips, observe and complete as many as possible of the following precautions and pre-installation procedures before going to the job site or beginning the installation.

IMPORTANT PRECAUTIONS

1. Prior to installation, inspect the pump for damage. Check for free pump and motor rotation. A slight drag is permissible.
2. Check to make certain that the voltage of the motor end and control agree with the available phase and voltage. Check power source. Check electrical supply for correct fusing, correct wire size, and adequate grounding and transformer size.

WARNING: Since most submersible pump problems are electrical, it is very important that all electrical work be done properly. Therefore, all electrical hook-up work or electrical service work should be done by a qualified electrician or service man only!

3. Throughout installation, take care not to damage the insulation of the electrical cable or motor leads. Never support the weight of the unit by electrical cable or motor leads.
4. Before the pump is installed, the well should be pumped free of sand and other foreign matter with a test pump. **The warranty is void if it is used to clean the well.**
5. Follow wiring directions in the control box and make momentary tests to see that motor runs. (It is normal to hear some noise from the pump when you are momentarily testing it). **Do not run pump dry for more than three (3) seconds.**

MAJOR WELL COMPONENTS (see Figures 1 & 2)

1. **Submersible Pump** — A submersible pump is a multi-stage centrifugal. Each stage consists of an impeller and diffuser. Water pressure increases in equal amounts as it passes from stage to stage. The more stages, the higher the pressure the pump will develop.
2. **Submersible Motor** — Submersible pumps can be powered by either single phase or three phase motors. Make certain that the motor corresponds with the horsepower required by the pump. Failure to do so, could result in overloading of the motor and motor damage.
3. **Control Box** — Single phase submersible motors require the use of an above ground control box for starting. Operation of these motors without control boxes or with incorrect boxes can result in failure of motors which will void the warranty.
4. **Magnetic Starters and Overload Protection** — Three phase submersible motors require the use of an above ground magnetic starter and overload protection. Operation of these motors without or incorrect starters and protectors will result in the failure of motor which will void the warranty. See Magnetic Starter Chart for the correct selection of magnetic starters and ambient compensated quick trip protectors.
5. **The Well** — The well should be sand free and have a sufficient flow of water to supply the pump. Clear well of sand and any other foreign matter with a test pump before installing the new submersible pump.

CAUTION: Using the submersible pump to clean the well will void the warranty.

6. When drilling a new well in an area where sand is a problem, a sand screen should be installed to protect the pump and motor.
7. The well should be straight so damage during installation does not occur to the pump or motor by becoming lodged in a crooked well casing.

8. The complete pump and motor should be submerged at least twenty feet below the draw down level of the well, and the motor should be a minimum of ten feet off the bottom of the well (Figure 4).

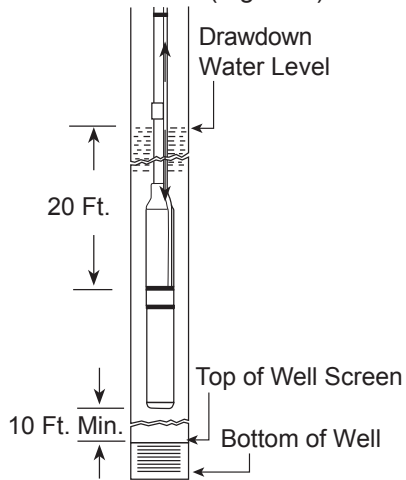

Figure 4

9. The Piping — Install the pump with pipe of the same diameter as the discharge port of the pump or larger.

NOTE: Use of pipe smaller than the discharge port of the pump will restrict the capacity of the pump and lower its operating performance.
 10. Check Valve — A check valve is required on all submersible installations. This valve maintains water within the pipe when the pump is running. A line check should be installed within 25 feet of the pump and below the draw down level of the water supply.
 - a. For well depths exceeding 200 feet, it is suggested that an additional check valve be installed every 100 feet.
 - b. An additional check valve should be installed in the horizontal line between the well top and the pressure tank (See Figures 1 & 2).

CAUTION: Make certain that the check valve is pointing in the right direction, arrow pointing towards the tank.
 11. Torque Arrester — To center the pump as it is being lowered into the well, a torque arrester is recommended. This will also minimize the pump whipping due to the starting torque of the motor (See Figure 2).
- NOTE:** On plastic pipe installations a torque arrester must be installed. Cable guards should also be installed.
12. Pressure Tank — The purpose of the pressure tank is to allow an amount of water to be drawn before the pressure drops enough to cause the pump to start. Without a pressure tank, the pump would start and stop continuously when water is drawn. There are two types of pressure tanks, the standard tank that requires an air volume control and the pre-charged tank.
 - a. On a standard pneumatic tank system, air is introduced to compensate for that which is absorbed by the water. Each time the pump cycles air is added to the tank through a bleeder and snifter valve. The excess air is released by

- a float assembly (air volume control) in the upper side tapping of the tank (See Figure 2).
 - b. In a pre-charged tank, a flexible diaphragm or bladder separates the air and water areas of the tank. The air chamber is pre-charged by means of a tire valve with pressure 2 PSI less than the cut-on pressure of the pump. Because the air is not in contact with the water, it cannot be absorbed by the water. Therefore, the original charge of air is never lost.
13. In pre-charged tank systems, none of the fittings for air introduction or air level control are required (Figure 1). The piping in the well is also different for the two systems. The pre-charged tank system does not require a bleeder orifice assembly, which simplifies the installation.

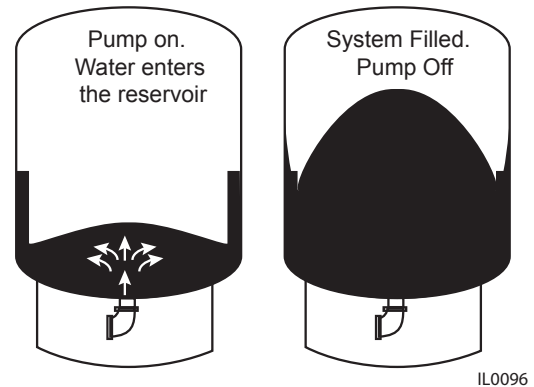

Figure 5

14. The tank size should be selected to keep the pump starts per day as low as practical for maximum life. Excessive motor cycling accelerates motor bearing and spline wear, pump wear and contact erosion. Use as a guide, 100 starts per day (24 hours) on single phase motors and 300 starts per day on three phase units.
15. Pressure Switch — The pressure switch provides for automatic operation. The pump starts when the pressure drops to the switch cut-in setting and stops when the pressure reaches the switch cut-out setting. The pressure switch must be installed as close to the tank as possible (Figures 1 & 2).
16. Pressure Relief Valve — A properly sized pressure relief valve must be installed on any installation where the pump pressure can exceed the pressure tank's maximum working pressure or on systems where the discharge line can be shut off or obstructed. The relief valve drain port should be piped to a drain (Figures 1 & 2).

WARNING: Not providing a relief valve can cause extreme over pressure, which could result in personal and/or property damage.

17. Pitless Adapter — A pitless adapter provides below grade discharge while maintaining above grade access to the well. Placed below the frost line they are frost proof and also prevent well contamination by providing a water tight seal between the vertical drop pipe and the horizontal service pipe connection (Figure 1).
18. Well Seal — On well seal installations the piping in the well projects above the well and is connected above ground to the system piping by means of a tee or elbow. Since the plumbing is above ground, it must be protected from freezing (Figure 2).
19. Submersible Cable — Submersible power cable must be UL listed for submersible pump application. Selecting the proper cable size is important. Undersized cable results in a too low voltage supply to the pump motor and ultimate motor failure. Oversized cable is costly and not necessary. Refer to cable selection chart for proper cable selection. Cable is selected for the maximum pump setting plus the offset distance to the service entrance.
20. Ground Wire — The National Electric Code (NEC 250-43) requires a separate ground wire be run down the well to the submersible pump and to be connected to all exposed metal parts of the pump and motor. Refer to the most recent National Electric Code (NEC) for additional grounding information. All wiring should be done by a competent electrician.

INSTALLATION

SUBMERSIBLE CABLE INSTALLATION

1. Check power source. Check electrical supply for correct fusing, correct wire size, and adequate grounding and transformer size.

WARNING: *Since most submersible pump problems are electrical, it is very important that all electrical work be done properly. Therefore, all electrical hook-up work or electrical service work should be done by a qualified electrician or serviceman only!*

2. Follow wiring directions in the control box and make momentary tests to see that the motor runs. **Do not run pump dry for more than three (3) seconds.** If test is satisfactory, proceed to Step 3 (cable splice).
3. First check cable size against the Submersible Wire Size Chart. Use extreme care; this is a very important step. If required length falls between two wire sizes, use the larger of the two wire sizes (smaller number).

IMPORTANT: Use of wire sizes smaller than those specified in the charts will cause low starting voltage, may cause early pump failure and will void the warranty. Larger wire sizes may always be used for better operating economy.

4. Splice motor leads to submersible cable with commercially available potting, heat shrink splicing kits or by careful tape splicing. Tape splicing should use the following procedure.
 - a) Strip individual conductor of insulation only as far as necessary to provide room for a stake type

connector. Tubular connectors of the staked type are preferred. If connector O.D. is not as large as cable insulation, build-up with rubber electrical tape.

- b) Tape individual joints with rubber electrical tape, using two layers; the first extending two inches beyond each end of the conductor insulation end, the second layer two inches beyond the ends of the first layer. Wrap tightly, eliminating air spaces as much as possible.
 - c) Tape over the rubber electrical tape with #33 Scotch electrical tape, (Minnesota Mining Co.) or equivalent, using two layers as in step "B" and making each layer overlap the end of the preceding layer at least two inches.
5. In the case of a cable with three conductors encased in a single outer sheath, tape individual conductors as described, staggering joints. Total thickness of tape should be less than the thickness of the conductor insulation.

GROUND WIRE INSTALLATION

WARNING: *Motor frame must be connected to power supply ground or fatal electrical shock may result.*

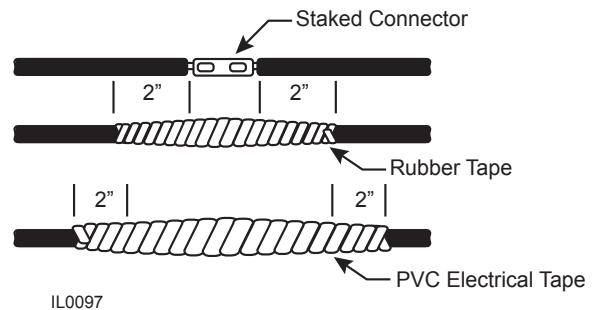

Figure 6

NOTE: All electrical wiring should be done by a competent electrician.

1. Grounding the submersible pump is accomplished by running a copper grounding wire from the pump motor to the main electrical system ground.
2. The ground wire to be used must be of the same size as the submersible power cable. It may be insulated or bare. If insulated, it must be green, with or without yellow stripe(s). The ground wire may be part of, or separate from, the supply cable. It may be continuous or spliced above the pump along with the supply cable.
3. The motor lead wire assembly includes a green insulated ground lead. Splice the ground wire to the green insulated lead as shown in Figure 6.
4. The other end of the ground wire will be connected to the power supply grounding terminal or to the control panel ground bar if it is connected to the power supply ground.

NOTE: See section entitled Grounding for detailed grounding instructions.

INSULATION AND CONTINUITY TEST

1. It is recommended that this test be done when the splicing is complete and pump is being test run in a tank of water. This test can be repeated after installation in well but before the final electrical hook-up is made to the control box or pressure switch (see Figures 7 & 8).

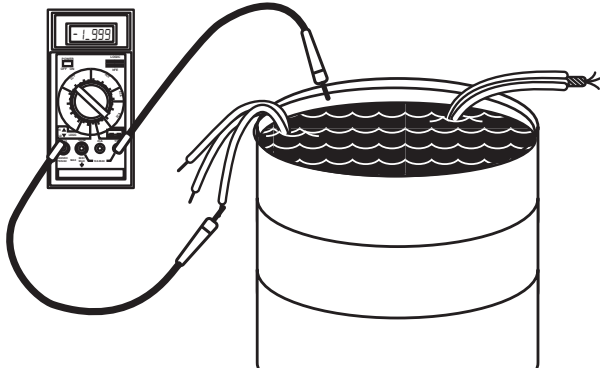

Figure 7

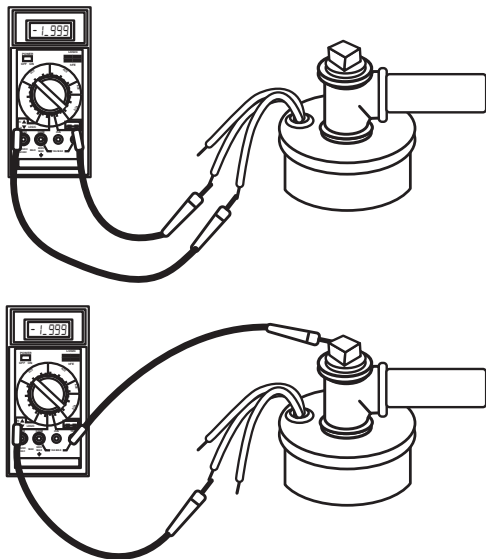

Figure 8

2. Zero the ohmmeter by clipping the leads together and adjusting the zero ohm knob until the needle indicates zero. Zero the ohmmeter before each use or every time selector switch is changed.
3. Clip one ohmmeter lead to bare cable end.
4. Clip the other lead to edge of steel tank in which pump and cable are submerged. If pump is already in the well, clip lead to discharge pipe metal well casing or bare ground wire.
5. A reading of less than 1,000,000 ohms indicates that cable or splice is grounded. Slowly raise cable from the water at the ohmmeter end. When trouble spot moves clear of the water, needle will move toward infinity reading. In an old installation with the pump in the well, a reading of 20,000 ohms or less indicates

a breakdown in the insulation; in this case pull the pump.

PUMP INSTALLATION

1. The following pump installation instructions use Schedule 80 PVC pipe or galvanized pipe. If either of these two types are used, a foot clamp or vise will be required to hold the PVC or galvanized pipe when connecting the next pipe length.
2. Install the pump in a well which is sand-free, straight, and has sufficient flow of water to supply the pump. Clear well of sand and any other foreign matter with a test pump before installing the submersible pump.

NOTE: Using the submersible pump to clean the well will void the warranty. When drilling a new well in an area where sand is a problem, a sand screen must be installed to protect the pump and motor.

3. Chlorinate the well first. Drop 24 to 48 HTH (chlorine) tablets into the well before lowering the pump into the well. This will prevent contamination and the growth of iron bacteria which could later plug the well and the pump. The chlorinated water will be pumped out of the system when testing the pump flow.
4. BE SURE the top edge of the well casing is perfectly smooth; sharp or jagged edges can cut or scrape the cable and cause a short.
5. Install a line check valve within 25 feet of the pump and below the draw down level of the water supply. The check valve should be the same size as the discharge outlet of the pump or larger.

NOTE: Use of pipe smaller than the discharge tapping of the pump will restrict the capacity of the pump and lower its operating performance.

6. When connecting the first length of pipe and placing the pump in the well casing, care should be maintained to center the pump in the well. It is easier to handle the pump if a short piece of pipe is installed first, rather than a long piece. Install the check valve at the end of the first piece of pipe prior to lowering the pump into the well. Maintain alignment as the pump is placed and lowered into the well, a torque arrester is recommended. Position the torque arrester to within 6" of the pump discharge and clamp arrester to pipe. Wrap the pipe with enough tape at top and bottom of torque arrester to keep it from sliding up the pipe while the pump is being lowered into the well.
7. If not already done, splice the electrical cable to the motor leads. The cable and ground wire should be taped to the discharge pipe. Tape the cable about 5 feet above the discharge and every 20 feet thereafter. Install cable guards if required to eliminate rubbing against the well casing. Do not let the cable drag over the edge of the well casing. Never allow the weight of the pump to hang on the cable alone.

- Lower the pump into the well slowly without forcing. Use a vise or foot clamp to hold the pipe while connecting the next length. A boom, tripod or pump setting rig is recommended. Lower pump to approximately 10 feet below maximum draw down of the water if possible and keep approximately 10 feet from the bottom. **DO NOT** set pump on bottom of well. Before each new length of pipe is added, attach the coupling to the top of the pipe length. This will provide a stop for the foot clamp to hold while the next section of pipe is being installed.
- On a standard tank with an air volume control a bleeder orifice is required. Install the bleeder orifice in the discharge pipe 5 feet or more below the sniffer valve. See Figure 2 and the table below.

Distance Table	
Tank Size Gallons	Depth From Horizontal Check Valve To Bleeder Orifice
42	5
82	10
120	15
220	15
315	20
525	20-35

Installations that use a pre-charged pressure tank do not require a bleeder orifice.

WELL SEAL/PITLESS ADAPTER INSTALLATION

- All installations should have a well seal. Make sure the seal is seated and tighten the bolts evenly.

NOTE: Be sure to assemble the tee to the pipe above the well seal to prevent dropping the pipe and pump down the well as you lower it.

IMPORTANT: Well seal and piping must be protected from freezing.

- On a pitless adapter installation, the connection to the system supply line is made below ground. Install the pitless adapter following the instructions included with particular brand or design being used in the installation.

NOTE: Follow ALL applicable state and local plumbing codes.

PRELIMINARY TEST RUN

- When pump is at desired depth, install throttle valve for preliminary test run. Wire single phase motors through the control box, following instructions in box regarding color coding of wires, etc. Wire 3-phase motors through a magnetic starter. Test cable for continuity with an ohmmeter.
- With pump discharge throttled, run pump until water is clear of sand or any other impurities. Gradually open discharge.

CAUTION: *Be sure you do not stop pump before water runs clear. This may take several hours. If pump stops with sand in it, it will lock.*

- If pump lowers water in the well far enough to lose prime, either lower pump in the well (if possible) or throttle discharge to capacity of the well.
- If well is low capacity, use a low water level control.

- On 3-phase units, establish correct motor rotation by running in both directions. Change rotation by exchanging any two of the three motor leads. The rotation that gives the most water flow is always the correct rotation.

PRESSURE TANK INSTALLATION

- On a new installation, install the pressure tank along with the pressure switch, pressure gauge, pressure relief valve, check valve, gate valves and unions as shown in Figures 1 & 2.
- On replacement pump installations be sure that the tank system is in good operating condition, as a water logged tank may cause pump failure.

ELECTRICAL HOOK-UP

WARNING: *Since most submersible pump problems are electrical, it is very important that all electrical work be done properly. Therefore, all electrical hook-up work or electrical service work should be done by a qualified electrician or serviceman only!*

WARNING: *Always disconnect power source before working on or near motor, its connected load or control box and wiring. If the power disconnect is out of sight, lock it in the open position and tag to prevent unexpected application of power.*

- Proceed with electrical hook-up matching cable colors and following the wiring diagrams (Figures 9, 10 & 11) or inside the lid of the control box.

WARNING: *Connect motor leads momentarily for correct rotation before installing pump in well.*

FUSE SIZES

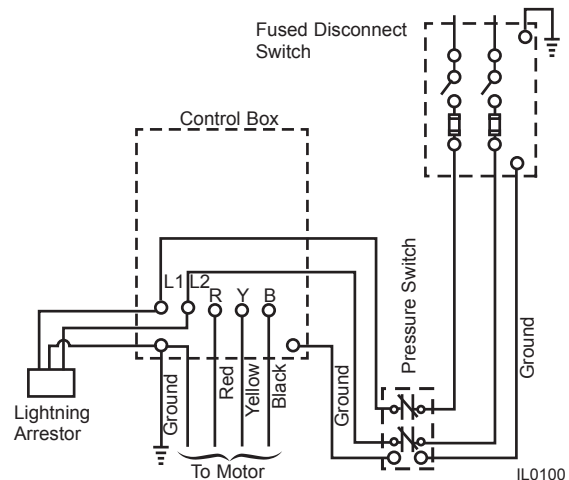

Figure 9 — Single Phase Control Box

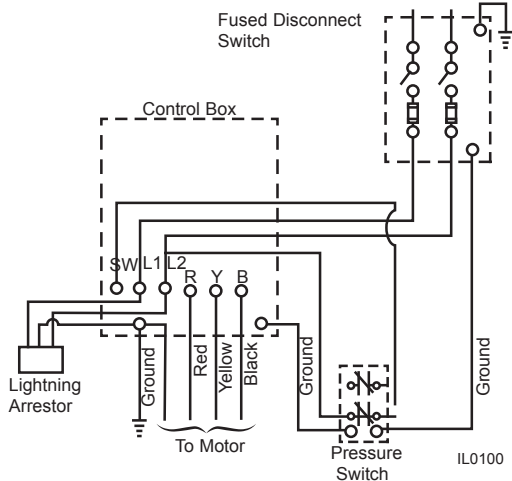

Figure 10 — Single Phase Control Box with Contactor

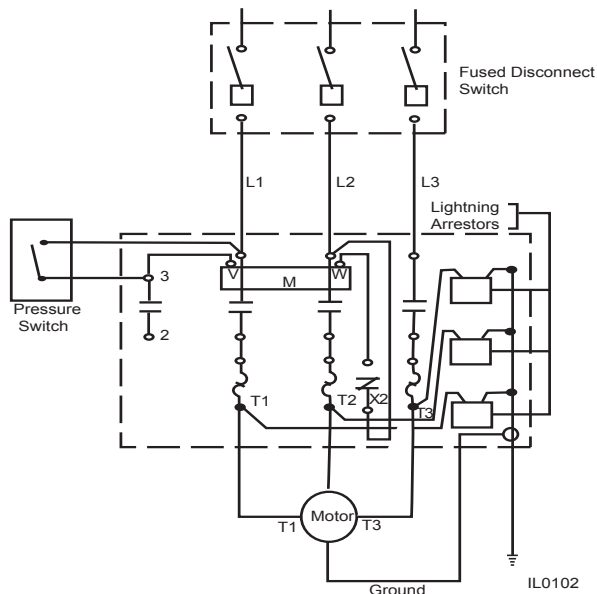

Figure 11 — Three Phase Magnetic Starter

1. For proper sizing of fuses for fuse disconnect box, see Motor Data Charts. Improperly sized fuses will result in fuses blown or circuit breakers tripped.

GROUNDING

Proper Grounding of Submersible Motors

1. The purpose of grounding any electrical apparatus is to prevent an electrical shock hazard if exposed metal becomes connected to an electrical circuit. This can occur from a defect in construction of the electrical equipment, physical damage, or a breakdown in the insulation of the equipment. Grounding prevents shock hazard by keeping exposed metal from reaching a voltage level which could endanger anyone coming in contact with the electrical equipment. Fault current is “drained” by the ground conductor, and if the fault is severe enough, the circuit will be opened by the fuse or circuit breaker.

2. The U.S. National Electrical Code (NEC) requires that motor-operated water pumps, including submersible type regardless of voltage, shall be grounded. The Canadian Electrical Code specifically discusses grounding requirements for submersible pumps. Interpretation of these and other codes may vary in different states and localities, but all applicable national, state, and local codes should always be followed.

3. Any submersible motor which is to be run tested out of the well should be grounded to prevent possible shock hazard during the test.

NOTE: Always disconnect all power when making ohmmeter check and while pulling or installing a pump.

4. The most logical way to “frame” ground a submersible motor is normally as follows:

- a. Run an extra wire with the motor power conductors. This wire must be sized to meet Table 250-95 in the U.S. National Electrical Code. If code information is unavailable, using the same size wire as the power conductors is normally adequate.
- b. The ground wire may be insulated or bare. If insulated, it must be green with or without yellow stripe(s). The ground wire may be part of, or separate from the supply cable. It may be continuous or spliced above the pump along with the supply cable.
- c. Connect the green or bare ground wire to the green ground wire of the submersible motor lead assembly. If the lead wire assembly does not include a separate ground wire, attach a lug to the ground wire and place the lug over one of the motor studs above the pump intake flange so the pump will not be cocked. The ground lug will then be secured with the nut which holds the pump on the motor.
- d. Connect the other end of the ground wire to the power supply grounding terminal or to the control panel ground bar if it is connected to the power supply ground.
- e. All connections should be tight and corrosion resistant, including screws, lugs or clamps.

Grounding Control Boxes

1. It is recommended the control box grounding terminal always be connected to circuits which include a grounding conductor. In fact, this is a requirement of the National Electrical Code. If the circuit has no grounding conductor and no metal conduit from the box to supply panel, use a wire at least as large as line conductors and connect from supply panel to the control box and to the motor lead ground wire.

WARNING: Failure to ground the box frame can result in a fatal electrical shock hazard if a circuit fault occurs.

WARNING: Serious or fatal electrical shock may result from failure to connect all metal plumbing, and the motor if outside a drilled well, to the power supply grounding terminal with wire no smaller than motor cable wires. Do not use motor in swimming area.

Grounding Lightning Arrestors In Control Boxes

1. When the box has a lightning arrestor, it must be grounded, metal to metal, all the way to the water strata for the lightning arrestor to be effective. Grounding the arrestor to a driven ground rod provides little or no protection for the motor.

SUBMERSIBLE MOTOR COOLING

1. When the pump is set below any screen openings or below the bottom of the casing a top feeding well condition can exist which reduces the rate of cooling water flow past the motor.
2. If the flow rate is less than specified a flow indicator sleeve or an alternate method of increasing water velocity past the motor must be used for proper cooling.

Minimum Velocity Past the Motor

4" dia. motor – .25 ft./sec. (7.62 cm/sec)

6" dia. motor – .5 ft./sec/ (15.24 cm/sec)

3. A flow inducer sleeve is a tube over the motor, closed off above the pump intake and extended to the bottom of the motor or lower. The sleeve material is corrosion resistant metal or heavy plastic (See Figure 12).

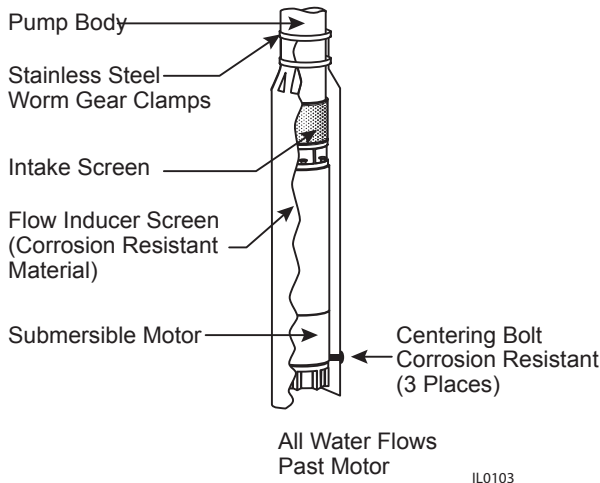

Figure 12

4. A flow inducer sleeve should always be used when the pump is in an open body of water. Make sure that such an installation is grounded.

Required Cooling Flow			
Minimum GPM required for motor cooling in water up to 86°F (30°C).			
Inches Casing or Sleeve I.D.	4" High Thrust Motor .25 ft/sec GPM	6" Motor .5 ft/sec GPM	8" Motor .5 ft/sec GPM
4	1.2	—	—
5	7	—	—
6	13	9	—
7	20	25	—
8	30	45	10
10	50	90	55
12	80	140	110
14	110	200	170
16	150	280	245

MAINTENANCE

SERVING SUBMERSIBLE MOTOR AND CONTROLS

1. The following is included to assist in motor installation and servicing. These procedures are limited to the motor and control system: they do not include pump requirements.

TIGHTENING LEAD CONNECTOR JAM NUT

1. It is recommended that possible damage from removal may prevent resealing. Torque the jam nut from 15 to 20 lb. ft. on 4" motor and 60 to 70 lb. ft. on a 6" motor.

CABLE IDENTIFICATION WHEN COLOR CODE IS LOST

(Single Phase Only)

If the colors on the individual drop cables cannot be determined and the leads cannot be positively identified, proceed as follows:

1. Disconnect all three drop cables from the control box. For temporary identification, tie a numbered tag to each cable (1, 2, 3).
2. Using an ohmmeter, check the resistance between cables as follows:

Unknown Value	Known Value
Cable 1 to Cable 2	Lowest - Black to Yellow
Cable 1 to Cable 3	Intermed. - Red to Yellow
Cable 2 to Cable 3	Highest - Black to Red

NOTE: The "yellow" cable is that giving lowest and intermediate readings and the "red" cables gives highest and intermediate readings.

Example:

- 1 to 2 gives 7 ohms (highest reading)
- 1 to 3 gives 5 ohms (intermediate reading)
- 2 to 3 gives 2 ohms (lowest reading)
- Cable 3 gave both intermediate and lowest reading
- Cable 3 is the yellow cable
- Cable 1 gave both highest and intermediate readings
- Cable 1 is the red cable
- Cable 2 is the black cable

The actual ohm values are not important. The method works regardless of the actual ohm readings; what matters is which reading is highest, which intermediate, and which lowest.

THREE PHASE POWER UNBALANCE

1. A full three phase supply is recommended for all three phase motors, consisting of three individual transformers or one three phase transformer. So-called "open" delta or wye connections using only two transformers can be used, but are more likely to cause problems from current unbalance.

2. Transformer ratings should be no smaller than listed in the table for supply power to the motor alone. Open Wye or Delta systems often suffer from line unbalance, which can cause poor motor performance, nuisance overload tripping, or premature motor failure. For the best performance current unbalance should not exceed 5 percent. If the unbalance cannot be corrected by rolling leads, contact the power company.

Transformer Capacity Required for Submersible Motors			
Motor HP	Total Effective KVA Required	Smallest KVA Rating — Each Transformer	
		Open WYE or DELTA 2 Transformers	Closed WYE or DELTA 3 Transformers
1-1/2	3	2	1
2	4	2	1.5
3	5	3	2
5	7.5	5	3
7-1/2	10	7.5	5
10	15	10	5
15	20	15	7.5
20	25	15	10
25	30	20	10
30	40	25	15
40	50	30	20
50	60	35	20
60	75	40	25
75	90	50	30
100	120	65	40

INSULATION RESISTANCE

Unbalance Formula

Percent

$$\text{Current} = \frac{\text{Max difference from average} \times 100}{\text{average}}$$

Example:

Currents are 80, 79, 84 amps (Lines 1-2 & 3)

$$\text{Avg. Currents} = \frac{80 + 79 + 84}{3} = 81$$

Percent

$$\frac{84 - 81}{81} \times 100 = 3.7\%$$

Current

Unbalance

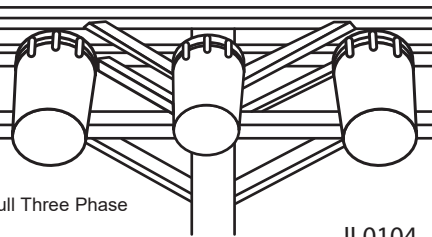
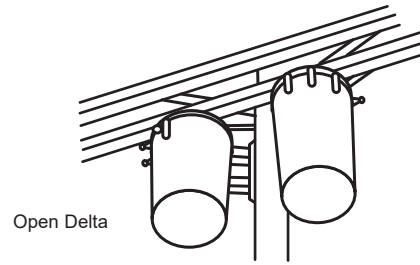

IL0104

Figure 13

Insulation resistance tests indicate the value of the motor, cable, and splice insulation system by measuring resistance in ohms between motor leads and ground. Low readings indicate a breakdown somewhere in the insulation system.

1. Set ohmmeter to RX100K or highest scale. (For best results use a megohmmeter).
2. Short meter leads together and adjust indicator to zero.
3. Be sure power is turned off!
4. Connect one meter lead to a motor lead and the other meter lead to ground.
 - a. If motor is out of water, measure from lead to motor frame.
 - b. If motor is installed in water, ground reference should be metal well casing (if submerged), metal drop pipe, or an extra wire extending into the ground water.
5. Readings and Conditions, motor installed in well:
 - a. 2,000,000 ohms or more - insulation completely acceptable.
 - b. 500,000 to 2,000,000 ohms - insulation in reasonably good condition. Acceptable. Should be considered marginal for new motor.
 - c. 20,000 to 500,000 ohms - insulation seriously damaged, but motor may still operate.
 - d. Less than 20,000 ohms - severe insulation damage. Motor probably not operable.

WINDING RESISTANCE

Winding resistance tests indicate whether or not windings are internally correct, shorted, or open. Winding resistance should be considered independently of insulation resistance readings.

1. Set ohmmeter to RX1. Short meter leads together and adjust indicator to zero.
2. Be sure power is turned off.
3. Connect ohmmeter between two motor leads.

- a. Three wire single phase: Yellow-Black indicates main winding resistance; Yellow-Red indicates start winding resistance.
 - b. Three phase: Resistance values should be equal on all three phases: Yellow-Black; Yellow-Red; Black-Red.
4. Correct readings should be equal to the Line-to-Line resistance values from the specifications section for a given motor, plus the resistance of the drop cable from the table below.
5. Conditions:

Resistance (Ohms) Per 100 Feet of Copper Cable (Round Trip)								
AWG	14	12	10	8	6	4	2	0
Ohms	.5	.3	.2	.12	.08	.05	.03	.02

- a. If one ohm value is less than specified, that winding is shorted.
- b. If one ohm value is greater than specified, that winding is open, or there is a poor connection in that circuit.
- c. On 3-wire single phase, if one ohm value is greater than specified and one ohm value is less than specified, the leads are mixed. See the section entitled "Cable Identification When Color Code Is Lost."

TESTING LOAD CURRENT AMPS

To test load current amps a clamp-on ammeter is required. Since the ammeter measures current flow, the motor must be running.

1. Pull the motor lead wire, being measured, (red, yellow or black) away from all other wires.
2. Set ammeter to the highest scale. (If starting a motor leave on the scale until current settles down).
3. Place tongs of meter around wire.
4. Change meter scale to one that gives the best accuracy. This will be a reading between mid scale and full scale.
5. Compare reading with current load amps on motors data chart.
6. Test each motor lead.

ONE YEAR LIMITED WARRANTY

This product is warranted for one year from the date of purchase or two years from the date of manufacture, whichever occurs first. Subject to the conditions hereinafter set forth, the manufacturer will repair or replace to the original consumer, any portion of the product which proves defective due to defective materials or workmanship. To obtain warranty service, contact the dealer from whom the product was purchased. The manufacturer retains the sole right and option to determine whether to repair or replace defective equipment, parts or components. Damage due to conditions beyond the control of the manufacturer is not covered by this warranty.

THIS WARRANTY WILL NOT APPLY: (a) To defects or malfunctions resulting from failure to properly install, operate or maintain the unit in accordance with printed instructions provided; (b) to failures resulting from abuse, accident or negligence or use of inappropriate chemicals or additives in the water; (c) to normal maintenance services and the parts used in connection with such service; (d) to units which are not installed in accordance with normal applicable local codes, ordinances and good trade practices; and (e) the unit is used for purposes other than for what it was designed and manufactured.

RETURN OF WARRANTED COMPONENTS: Any item to be repaired or replaced under this warranty must be returned to the manufacturer at Kendallville, Indiana or such other place as the manufacturer may designate, freight prepaid.

THE WARRANTY PROVIDED HEREIN IS IN LIEU OF ALL OTHER EXPRESS WARRANTIES, AND MAY NOT BE EXTENDED OR MODIFIED BY ANYONE. ANY IMPLIED WARRANTIES SHALL BE LIMITED TO THE PERIOD OF THE LIMITED WARRANTY AND THEREAFTER ALL SUCH IMPLIED WARRANTIES ARE DISCLAIMED AND EXCLUDED. THE MANUFACTURER SHALL NOT, UNDER ANY CIRCUMSTANCES, BE LIABLE FOR INCIDENTAL, CONSEQUENTIAL OR SPECIAL DAMAGES, SUCH AS, BUT NOT LIMITED TO DAMAGE TO, OR LOSS OF, OTHER PROPERTY OR EQUIPMENT, LOSS OF PROFITS, INCONVENIENCE, OR OTHER INCIDENTAL OR CONSEQUENTIAL DAMAGES OF ANY TYPE OR NATURE. THE LIABILITY OF THE MANUFACTURER SHALL NOT EXCEED THE PRICE OF THE PRODUCT UPON WHICH SUCH LIABILITY IS BASED.

This warranty gives you specific legal rights, and you may have other rights which vary from state to state. Some states do not allow limitations on duration of implied warranties or exclusion of incidental or consequential damages, so the above limitations may not apply to you.

In those instances where damages are incurred as a result of an alleged pump failure, the Homeowner must retain possession of the pump for investigation purposes.

Single Phase Control Box Checking and Repairing Procedures							
CAUTION: Turn power off and discharge capacitors before using ohmmeter.							
TEST PROCEDURE							
General Procedures	<ol style="list-style-type: none"> 1. Disconnect line 2. Inspect for damaged or burned parts, loose connections, etc. 3. Check for misconnections against diagram in control box 4. If problem has not been found, check motor per Motor Data Chart and control box as indicated below 						
Use of Ohmmeter	<ol style="list-style-type: none"> 1. Ohmmeter such as Simpson Model #372 or #260, Triplett Model #630 or #666 may be used 2. Whenever scales are changed, short ohmmeter leads and "zero balance" meter 						
Ground (Insulation Resistance) Test	<ol style="list-style-type: none"> 1. Ohmmeter Setting: Highest scale (usually R x 100K or 4 x 10,000) 2. Terminal Connections: One ohmmeter lead to "Ground" terminal on control box and touch other lead to each of the other terminals on terminal board 3. Ohmmeter Reading: Pointer should remain at (∞) and not deflect 						
Overload Protector	<ol style="list-style-type: none"> 1. Ohmmeter Setting: R x 1 2. Terminal Connections: Connect one ohmmeter lead to Terminal Black and other lead to: <ol style="list-style-type: none"> a. Terminal L₁ in four-terminal boxes b. Terminal L₂ in five-terminal boxes. 3. Ohmmeter Reading: Should be 0 to 0.5 ohms maximum 						
Capacitor Tests	<ol style="list-style-type: none"> 1. Ohmmeter Setting: R x 1,000 2. Terminal Connections: One ohmmeter lead to relay terminal #1 and other to black terminal on terminal board 3. Ohmmeter Reading: Pointer should swing toward "zero" and "float" back to (∞). Capacitor is shorted if pointer does not move back to (∞), open if it does not move from (∞) 4. If reading is not as above, disconnect capacitor from overload and test each component 						
Relay Coil Test (potential relays only)	<ol style="list-style-type: none"> 1. Ohmmeter Setting: 4 x 1,000 (or R x 100) 2. Terminal Connections: #6 and #2 on Relay 3. Ohmmeter Reading: <table style="margin-left: auto; margin-right: 0;"> <tr> <td></td> <td style="text-align: right;">For 230 Volt Boxes</td> </tr> <tr> <td style="text-align: right;">G.E.</td> <td style="text-align: right;">4.5 - 7.0 (4500-7000 ohms)</td> </tr> <tr> <td style="text-align: right;">Cardinal</td> <td style="text-align: right;">2.8 - 4.2 (2800-4200 ohms)</td> </tr> </table> 		For 230 Volt Boxes	G.E.	4.5 - 7.0 (4500-7000 ohms)	Cardinal	2.8 - 4.2 (2800-4200 ohms)
	For 230 Volt Boxes						
G.E.	4.5 - 7.0 (4500-7000 ohms)						
Cardinal	2.8 - 4.2 (2800-4200 ohms)						
Relay Contact Test (potential relays only)	<p>Most of the cases of inoperative relay contacts can be detected as follows:</p> <ol style="list-style-type: none"> 1. Ohmmeter Setting: 4 x 1. 2. Terminal Connections: Terminal #1 and Terminal #2 on Relay. 3. Ohmmeter Reading: Should be "zero". <p>NOTE: This test verifies "making" of contacts. If it is desired to test "Opening" and closing of contacts:</p> <ol style="list-style-type: none"> a. Connect control box components in control box as indicated on diagram in control box cover. b. Connect three leads from motor of correct rating to control box terminal board. c. Connect power source voltage to L₁ and L₂. d. Current in Red lead should momentarily be a high value - then drop (within one second) to values on Motor Data Chart <ol style="list-style-type: none"> 1. Disconnect one coil lead. 						
Contactors Test	<ol style="list-style-type: none"> 2. Ohmmeter setting R x 100. 3. Check coil resistance: 180 to 1400 ohms. 4. Remove contact cover and inspect contacts. 						

Troubleshooting Chart		
Symptom	Possible Cause(s)	Corrective Action
Fuses blow when motor starts	<ol style="list-style-type: none"> 1. Incorrect voltage 2. Incorrect fuses 3. Defective pressure switch 4. Control box malfunction 5. Bound pump 6. Defective cable or motor winding 7. Shorted or open motor winding 	<ol style="list-style-type: none"> 1. Contact power company if voltage is incorrect after first checking for correct wire size. See Wire Size Chart 2. Replace with proper fuses 3. Replace pressure switch or clean contacts 4. Correct faulty wiring or tighten loose contacts 5. Sand bound pump can sometimes be corrected by temporarily reversing black and red leads in control box then returning to normal. If pump does not rotate freely, it must be pulled and cleaned or realigned and the well condition corrected 6. The pump must be pulled and the cable disconnected and inspected. Damaged cable should be correctly spliced or replaced. If cable is good, the motor winding is grounded 7. The pump must be pulled and motor or drop cable repaired or replaced
Motor runs but fuses blow	<ol style="list-style-type: none"> 1. Incorrect voltage 2. Overheated protectors 3. Improperly wired control box 4. Defective motor or cable 5. Defective pump 6. Defective installation 	<ol style="list-style-type: none"> 1. Contact power company in incorrect 2. Shade box, provide ventilation or move box away from heat source 3. Rewire correctly 4. If ground, short or open circuit is indicated pump must be pulled for repair 5. Pull pump, clean and repair 6. Pull pump, rechecking components and installation
Motor does not start and fuses do not blow	<ol style="list-style-type: none"> 1. No power 2. Defective pressure switch 3. Defective wiring 	<ol style="list-style-type: none"> 1. Replace fuses or reset circuit breaker. Contact power company if no power is reaching box 2. Replace pressure switch or clean contacts 3. Correct faulty wiring or connections
Pump runs, but delivers little or no water	<ol style="list-style-type: none"> 1. Air locked pump 2. Low water level in well 3. Pump rotation wrong 4. Check valve stuck or installed improperly 5. Leak in drop pipe 6. Pump screen locked 7. Worn pump 8. Loose or broken motor shaft 	<ol style="list-style-type: none"> 1. Normal delivery may resume if pump is started and stopped at one minute intervals 2. Throttle pump delivery through restricting valve. Lower pump setting if depth of well is adequate 3. Check wiring connections 4. Replace or reinstall properly 5. Raise pipe, check for leak and replace damaged section 6. Clean screen and reset at less depth. It may be necessary to clean well 7. Pull pump and replace worn impellers, casing or other close fitting parts 8. Check for damaged shafts if coupling is loose and replace worn or defective units
Pump keeps running	<ol style="list-style-type: none"> 1. Pressure switch 2. Low level well 3. Leak in system 4. Worn pump 	<ol style="list-style-type: none"> 1. Clean points or replace switch 2. Throttle pump output or reset pump to lower level. Do not lower if sand may clog pump 3. Replace damaged section 4. Pull pump and replace
Pump starts too often	<ol style="list-style-type: none"> 1. Pressure switch 2. Leak in system 3. Check valve 4. Air supply (waterlogged tank - air under pressure absorbed into the water) 	<ol style="list-style-type: none"> 1. Reset limit or replace switch 2. Repair or replace tank or pipes 3. Remove and replace if defective 4. Clean or replace. Drain and recharge tank