



Commander® Pro Variable Speed Controller System Instructions

DESCRIPTIONS AND FEATURES

The Commander® Pro Variable Speed Controller is a dependable water system Variable Frequency Drive (VFD) that uses custom programming to enhance the performance of submersible pumps. When applied correctly to three phase motor driven pumps, the drive eliminates pressure cycling associated with conventional pressure switch controlled water pumping systems and provides a constant output pressure.

Key features of the drive controller include:

- Can use either a pressure switch (no snap action) or a 4-20mA transducer as the pressure control. At initial power up, the controller detects whether a switch or transducer is connected and automatically sets the control choice.
- Constant water pressure with a wide range of settings (30-80 psi) (Note: The maximum obtainable system pressure is limited by the performance of the pump installed)
- Smaller pressure tank can be used
- Fits the pump to the application – pump speed is controlled to provide the optimum performance without overloading the motor
- No in-rush (power-on transient) current
- Low motor start-up current (soft-starting)
- Active Power Factor Correction minimizes input RMS current

- Protection features
 - Dry run conditions – using intelligent load monitoring (see Page 7)
 - Bound pump – with auto-reversing torque
 - High voltage / lightning surge
 - Low line voltage
 - Short circuit

INCLUDED ITEMS:

- A. Controller Unit
- B. Pressure switch or Transducer
- C. Switch or Transducer Cable
- D. Installation Manual
- E. Small Screwdriver
- F. Warranty Card
- G. Switch Adjustment Tool (VS Systems only)

OWNER INFORMATION

System Model Number _____
 Pump Model / Date Code _____
 Pump Serial Number (Silver Label) _____
 Motor Model / Date Code _____
 Motor Serial Number (Silver Label) _____
 Controller Model / Date Code _____
 Dealer _____
 Address _____
 Install Date _____

TABLE OF CONTENTS

| | |
|--|---|
| Safety Instructions | 2 |
| System Components | 3 |
| Piping & General Information | 3 |
| Controller Location Selection | 4 |
| Controller Installation / Wiring | 5 |
| Start-up Operation | 6 |
| System Troubleshooting | 9 |

IMPORTANT SAFETY INSTRUCTIONS

Rules for safe installation and operation.

Read these warnings and instructions carefully. Failure to follow them could cause serious bodily injury and/or property damage.

▲ WARNING



Follow all local electrical and safety codes as well as the National Electrical Code (NEC) and the Occupational Safety and Health Act (OSHA).

The power supply should be a separate circuit, independent of all other circuits. Be sure it is equipped with a fuse and disconnect box of ample capacity.



For fire protection, the power supply should be free of any building, preferably on a direct line from the transformer. In the event of fire, the wires will not be destroyed and the water supply not cut-off.



Always disconnect power source before performing any work on or near the motor or its connected load. If the power disconnect point is out-of-sight, lock it in the open position and tag it to prevent unexpected application of power. Failure to do so could result in fatal electrical shock.



DO NOT handle pump with wet hands or when standing in water as fatal electrical shock could occur. Disconnect main power supply before handling pump for any reason.

Shut off power source when voltage drops below 210 on 230 volt installations.

Protect the power cable from coming in contact with sharp objects, oil, grease, hot surfaces or chemicals. DO NOT kink the power cable. If damaged replace immediately.

NEVER leave the control box, fused disconnect switch, or covers open (either partially or completely) when not being worked on by a competent electrician or repairman.



Always use caution when operating electrical controls in damp areas. If possible, avoid all contact with electrical equipment during thunderstorms or extreme damp conditions.

Install all electrical equipment in protected area to prevent mechanical damage which could produce serious electrical shock and/or equipment failure.

Pump is designed to pump cold ground water that is free of air or gases. Decreased pump performance and life expectancy can occur if the ground water is not cold (86°F/30°C) or contains air or gases.



Pump and controls must be securely and adequately grounded as specified in section 250-43 item (A) of the U.S.A. National Electric Code (NEC) and Section 26-954 Canadian Electrical Code. Failure to do so could result in a fatal injury.

DO NOT use this pump to pump flammable liquids such as gasoline, fuel oil, kerosene, etc. Failure to follow the above warning could result in property damage and/or personal injury.



The pump is intended for use in a well. Motor frame must be connected to power supply ground or fatal electrical shock may result. Do not use this pump in swimming pools.



Capacitors inside the drive controller can still hold a lethal voltage even after power has been removed. Allow 10 minutes for dangerous internal voltage to discharge before making changes to input power or motor connections.



Do not use motor or system in swimming areas.

▲ CAUTION

Do not use power factor correction capacitors with the drive controller. Damage will result to both motor and drive.

This equipment should be installed by technically qualified personnel. Failure to install it in compliance with national and local electrical codes and within stated recommendations may result in electrical shock hazard, fire hazard, unsatisfactory performance, or equipment failure.

NOTE: Units with the "ETL/CUS" mark are tested to UL standard UL508C & CSA standard C22.2 No. 274.

SYSTEM COMPONENTS

Please be sure that you have all major system components necessary to properly install the submersible pump system. Other components may also be necessary depending on the application requirements.

1. Submersible pump end
2. Submersible motor
3. Variable speed controller
4. Pressure tank
5. Pressure switch or transducer (packaged with controller)
6. Pressure relief valve (purchased separately)
7. Pressure gauge (purchased separately)

PIPING

General Information

The system is capable of flows up to 40 GPM. Discharge piping is recommended to be 1.25" for installations in which flows will exceed 12 GPM. The use of smaller pipe will increase friction losses and can severely limit the maximum capacity of the system.

This pump may be capable of pressures exceeding 325 PSI under maximum conditions, select pipe accordingly. Consult your pipe supplier to determine the best pipe material for the installation

Pump Inspection

Prior to installation check the pump, motor, controller and tank for shipment damage.

Pressure Tank

The Air-E-Tainer® tank supplied with your system has a factory set pre-charge of 35 PSI. Installer must recheck to make sure tank is still 35 PSI. This is 70% of the factory preset operating pressure of 50 PSI. Any change in operating system pressure will require that the pre charge in the tank be modified to 70% of that pressure. See Tank Table for minimum pressure tank size.

MINIMUM PRESSURE TANK SIZE (TOTAL CAPACITY)

| Controller | Pump Flow Rating less than 12 GPM | Pump Flow Rating 12 GPM or higher |
|------------|-----------------------------------|-----------------------------------|
| VS15/TVS15 | 4.6 Gal (132477) | 4.6 Gal (132477) |
| VS20/TVS20 | 4.6 Gal (132477) | 14 Gal (132661) |
| VS30/TVS30 | 14 Gal (132661) | 14 Gal (132661) |
| TVS50 | 14 Gal (132661) | 20 Gal (132662) |

▲ WARNING

Many pumps can develop excessive pressure, resulting in equipment and property damage as well as possible injury. Always install a pressure relief valve capable of passing full pump flow at 100 PSI. Install the pressure relief valve between the pump and pressure tank.

PRESSURE SETTING GUIDE

| System Pressure (at Pressure Sensor) | Pressure Tank Setting (PSI) (+/- 2 psi) |
|--------------------------------------|---|
| 25 | 18 |
| 30 | 21 |
| 35 | 25 |
| 40 | 28 |
| 45 | 32 |
| 50 (factory set) | 35 |
| 55 | 39 |
| 60 | 42 |
| 65 | 46 |
| 70 | 49 |
| 75 | 53 |
| 80 | 56 |

Pressure Relief Valve

The pressure relief valve and the discharge outlet need a flow rating which exceeds the flow capacity of the installation at the relief pressure. When located in an area where a water leak or relief valve blow-off may damage property connect an adequate drain line to the pressure relief valve. Run the line to a suitable drain or to an area where the water will not damage property.

▲ WARNING

Not providing an adequate relief valve can cause extreme overpressure which could result in personal and/or property damage. It is recommended that you manually activate the valve monthly to keep it in good working order.

Discharge Pipe

When discharge piping requires an adapter it is recommended that a stainless steel adapter be used. Galvanized fittings or pipe should not be connected directly to the stainless steel discharge head of the pump as galvanic corrosion may occur. Barb type connectors should always be double clamped. Torque arrestors are not required on this installation due to the soft starting characteristics of the motor and controller

Check Valve

A check valve is factory installed in the discharge head of the submersible pump. This maintains water within the pipe when the pump is not operating. For well depths exceeding 100 feet, an additional check valve should be installed every 100 feet.

Safety Rope

A safety rope eyelet is provided at the discharge of the pump. It is recommended to attach a nylon safety rope. This will assist in the removal of the pump and also prevent loss of the unit in the bottom of the well due to a loose fitting or pipe deterioration.

CONTROLLER LOCATION SELECTION

The NEMA 3R controller is intended for indoor and outdoor use and for operation in ambient temperatures up to 125° F (50° C). It should be mounted in a location that provides protection from water sprays greater than 30° from vertical. The drive should only be accessed by trained and authorized personnel. To ensure maximum weather protection, the unit must be mounted vertically with the cover properly aligned and secured with all lid screws. The following recommendations will help in selection of the proper location of the unit:

1. A tank tee is recommended for mounting the tank, pressure switch/transducer, pressure gauge, and pressure relief valve at one junction. If a tank tee is not used, the pressure switch/transducer should be located within 6 ft. (1.8 meters) of the pressure tank to minimize pressure fluctuations. There should be no elbows between the tank and pressure switch/transducer.
2. The unit should be mounted on a sturdy supporting structure such as a wall or supporting post - please account for the fact that the unit weighs approximately 20 lbs.
3. The electronics inside the controller are air-cooled. As a result, there should be at least **6 inches** of clearance on each side and below the unit to allow room for air flow.

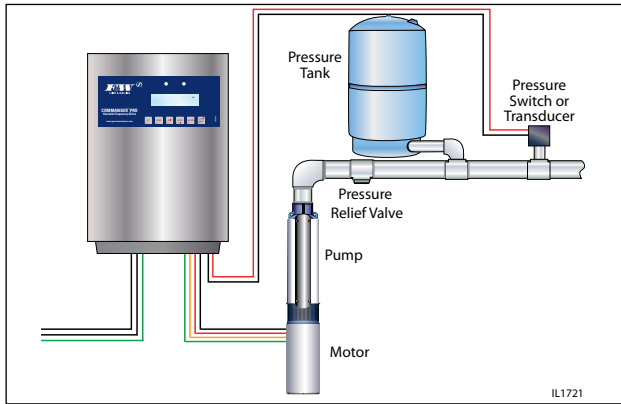

Figure 2 Location Diagram

⚠ CAUTION

There should be at least 6 inches of clearance on each side and below the unit to allow room for proper air flow. There are to be no elbows between the tank and pressure switch.

4. The controller should only be mounted with the wiring end oriented downward. If possible for best cooling, the controller should not be placed in direct sunlight or other locations subject to extreme temperatures or humidity (mounting location should not be subjected to condensation).
5. The mounting location should have access to 230V electrical supply and to the submersible motor wiring.
6. Do not expose the drive to water spray greater than 30° from vertical.

Note: Installations that require larger than 6 AWG wire will require an external junction box. Run 6 AWG from the drive

to the junction box and make external connections to the appropriately sized wire with wire nuts.

WIRING SIZING CHART

| Maximum Wire Lengths Connecting the Controller to The Main Circuit Box (Based On 3% Voltage Drop At 230V) | | | | | | | | | | |
|--|------------------------|----|-----|------|-----|-----|-----|-----|-----|-----------------|
| Motor HP | Copper Wire Size (AWG) | 14 | 12 | 10 | 8 | 6 | 4 | 3 | 2 | Circuit Breaker |
| 1.5/2 | Max. Length. (Ft.) | | 85* | 140* | 220 | 345 | 550 | 680 | 895 | 20 AMP |
| 3 | | | | 115* | 180 | 285 | 455 | 560 | 740 | 25 AMP |
| 5 | | | | | 115 | 185 | 290 | 360 | 470 | 40 AMP |

* Wire with 90°C Insulation only

PUMP WIRING

If submersible pump type is chosen, the output of the drive is 3-phase. (If the option is available, 3-wire may be available for submersible pumps).

The power output terminals (for motor wire connections) are located on the lower right-hand side of the controller and are labeled RED, BLK, YEL and (⊥). To select the wire size refer to the pump owner's manual, NEC and local codes for proper wire size.

NOTICE: Regardless of owner's manual, wire length should not exceed 1000 ft.

If the Commander Pro Controller is used with above ground motors the output is limited to 3-phase. To maximize motor life the cable length between the controller and the motor should be limited to a maximum length of 25 ft. Refer to the pump owner's manual, NEC and local codes for proper wire size. Caution: Correct motor rotating needs to be verified to avoid pump and motor damage.

⚠ CAUTION

Due to the inherent voltage changing characteristics of variable frequency drives (VFD), there is additional stress placed on the insulation of the wire between the controller and the motor compared to a standard pump system. Extra care must be taken when using Un-jacketed Flat Parallel Pump Cable to ensure that the insulation on each of the separated wires is the same thickness. Care must also be taken to ensure a proper seal with shrink tubing on any splices. Failure to take these precautions can lead to "wire burn through" that will shut down the system. Under these circumstances, no permanent damage usually occurs to the controller or motor. For further details call Technical Support at 800-742-5044.

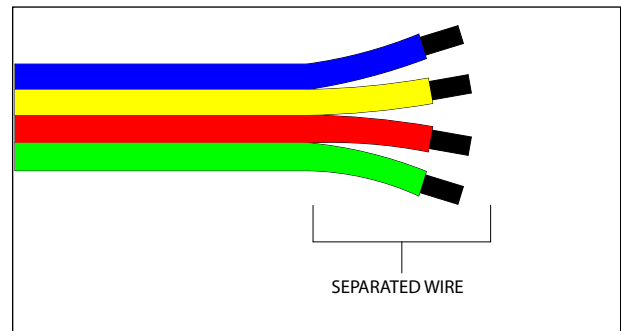

Figure 3 Wire Illustration

NOTE: DO NOT USE ALUMINUM WIRE.

Attention: To meet full compliance with FCC Part 15 Subpart B and CENELEC EN 55011, shielded motor cable should be used between the drive motor output and the motor. Using shielded cable provides the maximum filtering to reduce radiated & conductive emissions which can cause interference with other devices.

CONTROLLER INSTALLATION PROCEDURE

1. Disconnect electrical power at the main breaker
2. Drain the system (if applicable)
3. Install pressure switch or transducer - the pressure switch or transducer has a 1/4 - 18 National Pipe Thread (NPT) connection.
4. Remove the controller cover by removing the lid screws. Attach the unit to the wall using mounting screws (not included).

Wiring Connections

1. Verify that the power has been shut off at the main breaker.
2. Verify that the dedicated branch circuit for the controller is equipped with the correct rating of circuit breaker.
3. Remove the controller lid.

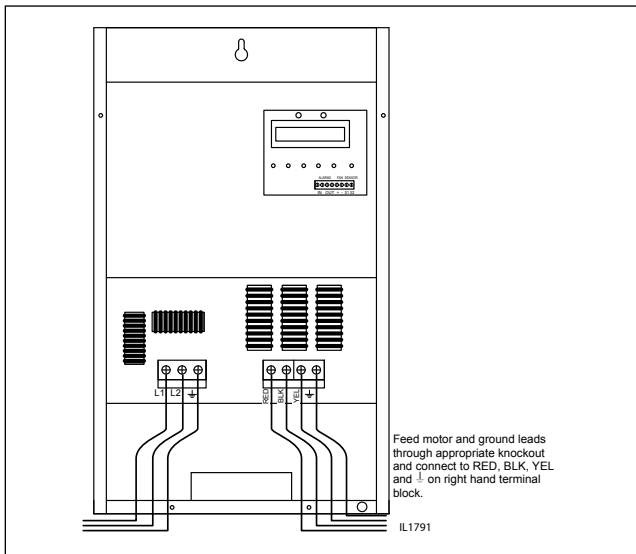

Figure 4

4. Feed the motor and ground leads through the appropriate knockout on the bottom right side of the unit and connect them to the terminal block positions. Submersible 3-Phase or 3-Wire 1-Ph motors: follow colors as marked: Red (RED), Black (BLK), Yellow (YEL) and ⚡. Submersible 3-Phase or 3-Wire 1-Ph motors: follow colors as marked: Red to RED, Black to BLK, Yellow (YEL) and Green Ground wire (⚡). Submersible 2-Wire 1-Ph motors: Connect motor leads to BLK, YEL and

Green Ground wire (⚡).

Above Ground Motor (3-Phase Only): L1 to RED, L2 to BLK, L3 to YEL and Green Ground wire (⚡)

CAUTION

Verify motor rotation to avoid damage to pump & motor.

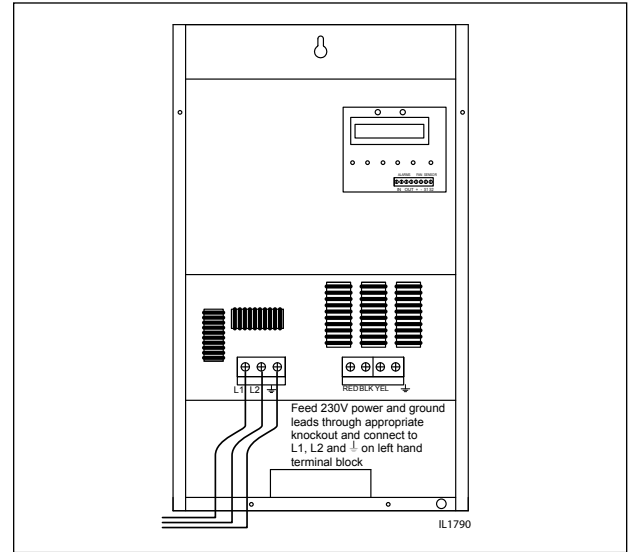

Figure 5

5. Feed the 230V power and ground through the appropriate opening on the bottom left side of the controller and connect them to the terminals marked L1, L2 and ⚡.

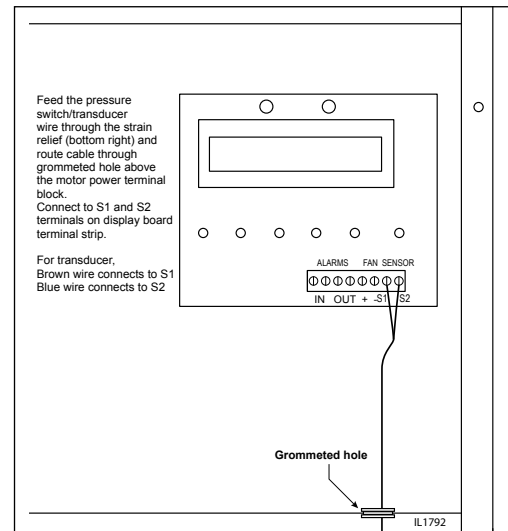

Figure 6

6. Install provided strain relief in the smaller hole on the bottom right hand side of the controller unit. Feed the pressure switch or transducer leads through the strain relief and route the leads through the grommetted hole above the motor terminals.
 - For Switch (VS Drive Kit): Connect the red and black lead wires to the terminals marked "S1" and "S2" (interchangeable) on the display board terminal strip with a small screwdriver (provided).
 - For Transducer (TVS Drive Kit): Connect the Brown wire to the terminal marked "S1" the Blue Wire to terminal

"S2" on the display board terminal strip with a small screwdriver (provided). Tighten the strain relief on the pressure switch/transducer lead.

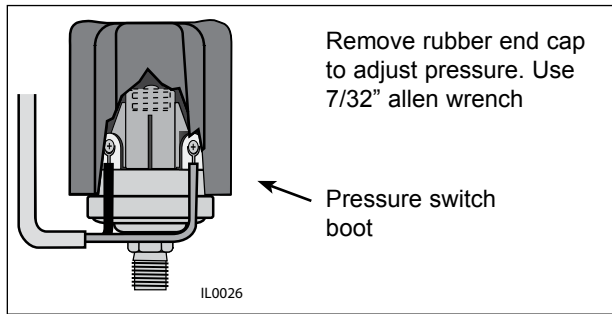

Figure 7 Pressure Switch

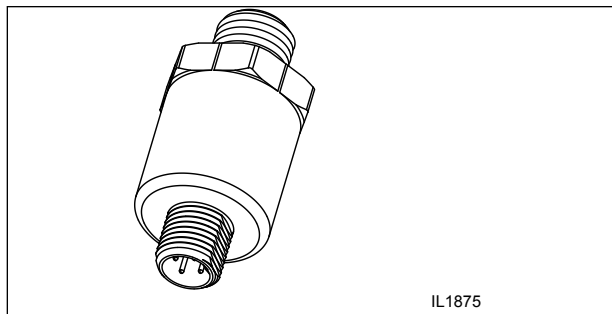

Figure 8 Pressure Transducer

A 10 foot section of cable is provided with the system to connect to the pressure switch / transducer. Lengths of up to 100 feet can be used, provided the appropriate shielded cabling is used. Consult the factory for proper cable specification.

7. Use the appropriate strain relief or conduit connectors (not included).
8. Replace the cover. Do not over-tighten the screws.
9. Set the pressure tank pre-charge to 70% of the desired water pressure setting. To check the tank's pre-charge, de-pressurize the water system by opening a tap. Measure the tank pre-charge with a pressure gauge at its inflation valve and make the necessary adjustments.

NOTE: For pressure switch installation (VS systems) only. Follow steps 10, 11 & 12. (Figure 7)

For pressure transducer installations, skip to Step 13.

10. Connect the other end of the pressure switch cable with the two spade terminals to the pressure switch. The connections are interchangeable.
11. The pressure switch communicates the system pressure to the controller. The switch is preset at the factory to 50 psi, but can be adjusted by the installer using the following procedure:
 - a. Remove the rubber end-cap.
 - b. Using a 7/32" Allen wrench (provided), turn the adjusting screw clockwise to increase pressure and counter-clockwise to decrease pressure. The adjustment range is between 30 and 80 psi (1/4 turn = approximately 3 psi).

- c. Replace the rubber end cap.
 - d. Reset the pressure tank pre-charge to the appropriate pressure
12. Cover the pressure switch terminals with the rubber boot provided.

For pressure transducer installation (TVS systems) only. Follow Step 13. (Figure 8):

13. Connect the free end of the transducer cable to the transducer by lining up the keyway on the connector to the transducer, pressing the cable into place & then tightening the thumbscrew finger tight.

START-UP OPERATION

Apply power to the controller. The display should briefly show "Please Wait Initializing" and then read "Press Enter to Begin Set-Up". Pressing ENTER button will begin taking you through the quick set-up menu where you can select Pump type (Submersible or Above Ground); Motor type (Three Phase, 3W Single Phase - if option is available); Maximum Motor Current; Maximum Frequency; Control (Switch, Transducer) by using the UP & DOWN buttons to change the setting and then pressing the ENTER button to save the choice. Once all the choices have been selected, press the STOP/ START button to save the setting to the controller's memory. The drive will then spin the motor in a reverse direction for a couple of seconds and then begin to run the motor in the correct direction and begin regulating the pressure. While the drive is running the motor, for VS drive kits (pressure switch) the display will show the current that the motor is drawing and the frequency that is being supplied. When there is no water use, the controller will shut off the output to the motor and the display will show "Motor is in Standby Mode". For TVS drive kits (transducer) the display will show the transducer pressure reading, current that the motor is drawing and the frequency that is being supplied.

NOTE: Conventional private water systems intermittently fill a pressure tank as commanded by a standard pressure switch (e.g. 30 - 50 psi). The constant pressure controller maintains a constant pressure at the pressure switch/transducer up to the maximum capability of the motor and pump. Although the pressure is constant at the pressure switch or transducer, pressure drops may be noticeable in other areas of the home when additional taps are opened. This is due to limitations in the plumbing and will be more pronounced the further the taps are from the pressure switch/transducer. This would be true of any system, and if observed, should not be interpreted as a failure in the performance of the constant pressure controller.

▲ WARNING

Serious or fatal electrical shock may result from contact with internal electrical components. DO NOT, under any circumstances, attempt to modify connections to the drive until power has been removed and 10 minutes have passed for internal voltages to discharge!

Underload Sensitivity

The controller is configured at the factory to ensure detection of Underload faults in a wide variety of pumping applications including dead head and run dry conditions. In very rare cases (as with certain pumps in shallow wells) this trip level may result in nuisance faults. If the pump is installed in a shallow well, activate the controller and observe system behavior. Once the controller begins to regulate pressure, check operation at several flow rates to make sure the default sensitivity does not induce nuisance Underload trips. If it becomes necessary to desensitize the Underload trip level, please call of Technical Support at 800-742-5044 for further details.

UNDERLOAD INTELLIGENT RESET

(Display shows Dry Well Trip)

If a motor Underload fault condition occurs, the most likely cause is an over-pumped well (dry well) or loss of incoming feed water to the pump. In a dry well situation to allow the well to recover, the controller will wait 30 seconds to 5 minutes, determined by the amount of time the motor had been running before sensing the dry well, before restarting the motor. For example, the first time the fault occurs and the pump has been running 6 minutes, the controller stop the motor and will wait 30 seconds before attempting to restart the pump. If the system would then run for 2 minutes and an dry well fault recurs, the controller will wait 3 minutes before attempting to restart the pump. This schedule allows for the minimum off-time possible based on the recovery time of the well.

If there is an obstruction (such as a closed valve) between the pump and the pressure switch/transducer, the controller will also sense an underload deadhead condition stopping the motor to avoid damaging the pump.

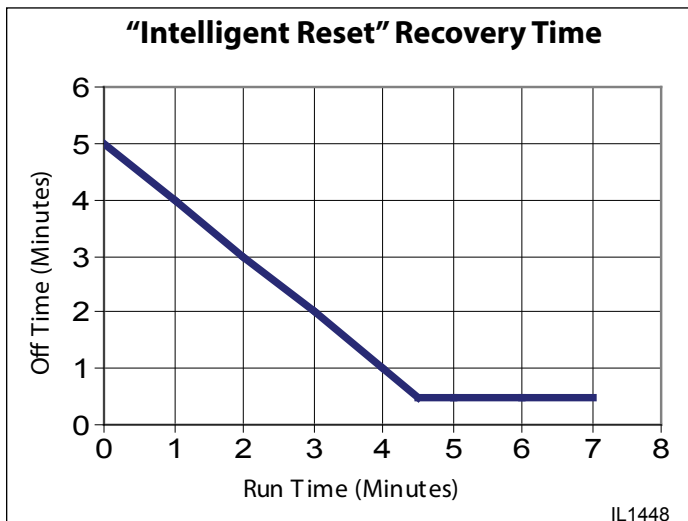

Over Temperature Protection

The controller is designed for full power operation in ambient temperatures to up to 125°F (50°C) as long as the input voltage is at 230V. Under severe thermal situations, the controller will reduce power output by reducing the output frequency in order to avoid shutting down. Full speed output is restored when the temperature cools.

External alarm trip terminals

The control is fitted with an Alarm In terminal block on the display board. Using these terminals, an external control switch can be wired to the drive. With this connection, an external control such as an over pressure, under pressure, timer, low level switch, etc. can be used to trip the drive with an "External Fault" trip. For this connection to work properly, the Alarm In Relay contact condition setting in the Advanced Features Menu must be set to match the switch position to activate the drive. (Example: An irrigation timer closes a contact to single the drive to run, the Alarm In Relay setting should be set to NC (Normal Closed) for the drive to be active during the irrigation cycle.)

This connection can also be used with the "External Control" feature in the advanced options menu to put the drive in standby rather than causing an external fault trip.

Caution: The external control must be a dry contact (i.e. no voltage applied to the Alarm In terminals of the controller) to not damage the drive circuit boards. An external control with voltage can only be used with the controller if an isolation relay is used in conjunction with the voltage source. Contact technical support for more information.

Leaky Systems (Pressure Switch Control)

Leaky water systems might keep the controller running due to the accurate pressure sensing capability of the pressure switch. Continuous running or starts and stops do not hurt the controller, pump or motor. However, to reduce the on-time of the controller/pump/motor, a "Bump-Mode" has been programmed into the drive. During very low flow (or leaky) conditions this feature periodically increases the speed of the pump several PSI above the set point and shuts off the pump. This adds some time to bleed off before the system starts up again. This "Bump-Mode" can be turned off or adjusted if desired. Please call Technical Support at 800-742-5044 for further details.

Fill Pipe Mode (Transducer Control)

At initial power up, the drive is automatically in the Fill Pipe Mode for 3 minutes. This allows a new installed system to fill the pip and build up pressure without having the pump trip out because it is sensing low pressure. If additional time is needed, this mode can be turned back on and the time increased in Parameter menu #7.

Use of Engine Drive Generators

There are several technical issues that go into correct sizing of a generator for use with a VFD controller. Since the VFD is a "non-linear load", the generator needs to be oversized considerably for proper operation. Listed below is minimum recommended sizing of a generator for each drive rating if the VFD controller is the only load on the generator. Because of the variation in design of voltage controls used in generators, the generator manufacture should always be contacted to verify the correct sizing when used with a VFD controller.

For best results when used with a generator in the Advanced Features Menu the **Powered by Generator option needs to be set to "Yes"**.

| VFD | Minimum Generator rating |
|----------|--------------------------|
| VS/TVS15 | 4.8kW |
| VS/TVS20 | 8.0kW |
| VS/TVS30 | 10.0kW |
| TVS50 | 15.7 KW |

Note: If additional loads are being supplied by the generator, the generator manufacture should be contacted for correct sizing. When the controller is being supplied power by a generator the Powered by Generator option should be set to YES in the advanced features menu to minimize possible damage to the drive.

Drive Configuration

When sized correctly, the drive controller package systems are fully programmed and are ready to go right out of the box without need for additional configuration. There are several parameters that can be changed:

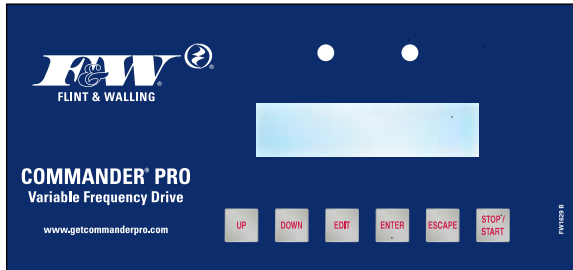

Figure 9 Display and Keypad

⚠ WARNING

Capacitors inside the drive controller can still hold a lethal voltage even after power has been removed. Allow 10 minutes for dangerous internal voltage to discharge before making changes to input power or motor connections.

By pressing and holding the EDIT & ENTER buttons down together for 5 seconds, you enter into the program menu. Using the UP & DOWN buttons, you can scroll through the menus and view the current settings. To make a change to a parameter press the EDIT button followed by the UP and DOWN buttons to set or choose the new value. Once the new values is set, press the ENTER button to accept the new value or the ESCAPE button to discard the change. Once you are done viewing and changing the parameters press ESCAPE to return to the home screen.

For further information to change these parameters, please call Technical Support at 800-742-5044.

| Access menu options by pressing and holding edit and enter for 3 seconds. | | |
|---|---|--|
| Menu Option | Action | Notes |
| KEY: | APPLIES ONLY TO TRANSDUCER | |
| | APPLIES ONLY TO PRESSURE SWITCH | |
| | APPLIES TO EITHER OPTION | |
| (1) Control Choice | Switch or Transducer | At initial power-up, the drive will detect what control devise is attached and will automatically set the control choice. If a switch or transducer is not hooked up, the drive will default to Switch as it's control choice. |
| Set Transducer Range (Only for Transducer Control) | 50-300 PSI Default 100 PSI | Programs the drive to the range of the pressure transducer that is attached. (Drive ships with 100PSI transducer.) |
| Set Pressure Set Point (Only for Transducer Control) | 15 - (Max Transducer range - 5) Default 50 | Target system pressure. |
| Set Draw Down PSI (Only for Transducer Control) | 2-15 PSI Default 5 PSI | Sets the amount that the system pressure has to drop below the set point while the drive is in standby before the drive will restart the motor. |

Access menu options by pressing and holding edit and enter for 3 seconds.

| Menu Option | | Action | Notes |
|---|---------------------------|---|--|
| (2) Maximum motor current | | Set Max Motor Amps. Default 1.5Hp Drive = 5.9 A Default 2.0Hp Drive = 8.1 A Default 3.0Hp Drive = 10.9 A | Protects the pump motor assembly from operating beyond its maximum capability. |
| (3) Maximum frequency | | Options 60, 70, 80 Hz. Default 80 Hz. | Setting frequency determines the maximum motor speed. For matched HP rating of motor & pump end, set to 60 Hz. For pump end of half the HP rating of the motor (i.e. 3/4HP pump & 1.5 HP motor), set to 80 Hz. |
| (4) Pass code enable | | (Y/N) Sets 5 digit pass code using Up/Down keys. Default No. | Pass code restricts parameters being changed by non-authorized individuals. If pass code lost, Call 1-800-345-9422 for assistance. |
| (5) Underload protection | | (On, Off, Prime) Turns underload protection on, off, or off for 30 minutes. Default ON. | Recommend that this is left On. Provides pump protection from deadhead or dry well conditions. May need to be Off/Prime when priming a centrifugal or if filling irrigation system. |
| | Set Deadhead trip point: | Default 1.5Hp Drive = 5.0 A Default 2.0Hp Drive = 6.4 A Default 3.0Hp Drive = 8.2 A | If the motor current falls below this set point when drive has ramped to maximum frequency, the drive will trip on Deadhead Fault. Adjust down in increments of .2 if experiencing nuisance deadhead trip. |
| | Set Dry well trip point: | Default 1.5Hp Drive = 3.9 A Default 2.0Hp Drive = 5.3 A Default 3.0Hp Drive = 6.5 A | If the motor current falls below this set point when drive has ramped to maximum frequency, the drive will trip on Dry Well Fault. Adjust down in increments of .2 if experiencing nuisance dry well trip. |
| | Set Dry well off time: | Off, 15 to 240 Min, 12 Hrs, or 24 Hrs. Default Off. | If set to "Off", dry well time is variable by Intelligent reset. This can be set to fixed time off before restarting in a range of 15 to 240 minutes in increments of 15 minutes, or 12 or 24 hours if desired. |
| (6) Bump mode (Switch Control Mode) | | (On, Off) Leak detection. Default On. | Turns On or Off a small pressure boost if the drive detects a very low load (leak condition). This will reduce the run time of the pump and drive. |
| | Set bump mode frequency: | Sets bump mode threshold frequency. Default 45 Hz. | When the drive is running for 15 seconds below this frequency. and current is below the BM current, the drive will ramp up for the BM duration regardless of switch state to create an overpressure drawdown. |
| | Set bump mode duration: | Sets the time duration of the ramp up for a bump in PSI (.5 to 2.0 sec.) Default 0.5 sec. | By increasing this duration time, the amount of overpressure for drawdown can be increased. Caution: Increasing this time too much has the potential of creating a high over pressure condition. |
| | Set bump mode current: | Sets bump mode threshold detection current. Default 1.5Hp Drive = 3.1 A Default 2.0Hp Drive = 4.7 A Default 3.0Hp Drive = 6.1 A | When the drive is running for 15 seconds below this current and the frequency is below the BM frequency, the drive will ramp up for the BM duration regardless of switch state to create an overpressure drawdown. |
| (6) Standby Sensitivity (Transducer Control Mode) | | Parameters for allowing the drive go into standby mode at no/low flow. | |
| | Set Standby frequency: | Sets Standby threshold frequency. Default 45 Hz. | When the drive is running for 15 seconds below this frequency. and current is below the standby current, the drive will begin ramping the motor speed down and monitor system pressure to go into standby mode. |
| | Set Standby Drawdown: | Sets the amount the system pressure can fluctuate after low load is sensed and still go into standby mode(.5 to 2.0 PSI) Default 0.5 PSI | By increasing this duration time, the amount of overpressure for drawdown can be increased. Caution: Increasing this time too much has the potential of creating a high over pressure condition. |
| | Set Standby current: | Sets Standby threshold detection current. Default 1.5Hp Drive = 3.1 A Default 2.0Hp Drive = 4.7 A Default 3.0Hp Drive = 6.1 A | When the drive is running for 15 seconds below this current and frequency is below the standby current, the drive will begin ramping the motor speed down and monitor system pressure to go into standby mode. |
| | Set Standby rate: | Sets Standby deceleration rate (5-35) Default 15. | This is the rate that the drive begins slowing down the motor to enter standby mode. |
| (7) Broken pipe mode | | (On/Off). Default ON. | Turn On/Off broken pipe trip. When On, if the drive is running the PMA continuously for the set time period, the drive will trip out on "Broken Pipe". |
| | Set broken pipe run time: | (1, 8, 16, 24, 48) Hours Default 24 Hours. | Define the time that the drive can run continuously before tripping on Broke Pipe. |

Access menu options by pressing and holding edit and enter for 3 seconds.

| Menu Option | | Action | Notes |
|---|---|--|--|
| (8) Advanced features | | | |
| | Drive parameters | View the current output Hz, Amps & heat sink temperature. | Used for diagnostic purposes in troubleshooting overheating drive. |
| | Motor Type | (Submersible/Above Ground) Change setting for the type of pump motor | This option is used to change the setting for the type of pump motor the control was set to use during the initial set-up menu. |
| | Manual run pump mode | (Off/On) Sets pump to run without pressure switch. Default OFF | Turn on a manual run condition at a set frequency for a defined amount of time. |
| | Set manual pump frequency: | (50, 60, 70, 80 Hz) Default 60 Hz. | Set the constant frequency (motor speed) of the Pump. (only required if manual mode ON) |
| | Set manual pump run time: | (1/2, 1, 4, 8, 16, 24, 48, Cont.) - Hours) Default 24 Hours. | Sets the time that the drive will run before shutting itself off. If set for Cont. (typically not recommended), the drive will run continuously until it is stopped manually. Broken pipe mode is not active when manual run is on. (only required if manual mode ON) |
| | External control mode | (Off/On). Default OFF. | Determines if the Alarm In contacts trips out the drive or just puts it in Standby Mode. If Off and the contacts wired to the Alarm In terminal blocks are inverse of the Alarm In Relay settings, the drive trips out on External Trip. (Used for protection like over pressure.) If On and the contacts wired to the Alarm In terminal blocks close, the drive goes to Standby Mode. (Used for control like a timer contact for an irrigation system.) |
| | Alarm In Relay | (NO/NC) Sets alarm in contact settings. Default NO. | If set to normally Open, drive will operate normally when the contacts are open & trip (or go to standby mode) when contacts close. (Example: An irrigation timer closes a contact to single the drive to run, the Alarm In Relay setting should be set to NC (Normal Closed) for the drive to be active during the irrigation cycle.) |
| | Drive status relay | (NO/NC) Sets alarm out relay as normally open or normally closed. Default NO. | The state of the relay changes when the drive trips. Typically not for use in most residential applications. |
| | Powered by Generator | (No/Yes) Default No. | Set the drive circuitry to expect power delivered from a gas driven generator. Depending upon application a 5-10% pressure drop of can be experienced when the drive is running the pump & motor at full speed. |
| | Ramp up sensitivity (Switch Control Mode) | (1, 2, 3, 4, 5) Sets Ramp Up speeds. Default 2. | If excessive pressure fluctuations on pressure gage is noticed, the ramp rates can be adjusted. |
| | Ramp down sensitivity (Switch Control Mode) | (1, 2, 3, 4, 5) Sets Ramp Down speeds Default 2. | If excessive pressure fluctuations on pressure gage is noticed, the ramp rates can be adjusted. |
| | Minimum Start-Up Time (Switch Control Mode) | 0.5-5 Seconds Default 1.3 | The minimum time the drive will ramp up when coming out of standby. |
| (9) Reset to factory defaults | | Resets drive to factory defaults | Resets the drive to the initial start-up menu for drive set-up. |
| (10) Control Settings (Transducer Control Mode) | | Advance control settings for use with Transducer. | |
| | Transducer Calibration | Used to calibrate transducer reading with external pressure gage. | |
| | Enter Pressure Gauge Reading | 20-80 PSI | Adjust value to match the pressure reading of the external pressure gauge & press enter. |
| | PID Set Points | Adjust Transducer feedback control parameters. | By increasing this duration time, the amount of overpressure for drawdown can be increased. Caution: Increasing this time too much has the potential of creating a high over pressure condition. |
| | Set PID Control P | 100-5000 Default: 400 | Adjustments can change the quickness of the drive reacting to pressure changes to reduce excessive pressure fluctuations. |
| | Set PID Control D | 1000-10000 Default: 5000 | |
| | Set PID Control I | 10-150 Default: 150 | |
| | Pipe Fill Mode | | |
| | Set Pipe Fill Time: | 1-15 Minutes Default 3 min. | Sets the time limit that pipe fill mode is active. |
| | Pipe Fill Mode | (On, Off) Fill Pipe Default: Off | Turns On/Off Fill Pipe mode. When Pipe Fill mode is on, the drive will not trip out on Deadhead/Low PSI fault. |

SYSTEM TRIP CODE TROUBLESHOOTING

Should an application or system problem occur, built-in diagnostics will protect the system. The red "FAULT" light on the front of the controller will flash and a fault condition will be shown on the display. In some cases, the system will shut itself off until corrective action has been taken. Fault codes and the recommended corrective action for each are listed in the following table. To view the trip codes in the recent trip log, press and hold the UP & DOWN keys at the same time for 1 second. The log will show the last 20 trips as well as the time in days, hours & minutes since the trip occurred. (Note: the trip time will only increment while the drive has power.) If no trips have been recorded, "No Fault" will be displayed in the log.

| Fault | Possible Causes | Corrective Action |
|---|---|---|
| KEY: | APPLIES ONLY TO TRANSDUCER | |
| | APPLIES ONLY TO PRESSURE SWITCH | |
| | APPLIES TO EITHER OPTION | |
| Short circuit | Shorted motor cables | Check motor wires and drop cable for shorts or bad connections |
| | Shorted motor | Replace motor |
| | Damaged wire insulation | Check drop cable for insulation damage |
| | Internal hardware short | If motor is disconnected and the fault is present when reset, replace drive. |
| Locked Rotor | Motor/pump misaligned | Verify Pump is mounted flush on motor mounting flange. |
| | Bound pump | Check for debris n pump |
| Transducer Found (Switch Control) | Drive set for Switch control, but a transducer signal was detected. | Change drive control choice from Switch to Transducer in Control Choice menu |
| Shorted Transducer (Transducer Control) | Drive has detected a short circuit between S1 & S2 terminals | Internal short of transducer. Replace transducer. |
| | Switch is hooked up between S1 & S2 | Replace switch with transducer. |
| Open Transducer (Transducer Control) | Transducer lead not connected properly to transducer (or cut) | Check transducer lead connection and/or replace transducer lead wire. |
| | Loose connection on terminals S1 & S2 | Check transducer lead connection at drive terminals S1 & S2 |
| | Transducer lead wire backwards at S1 & S2 terminals | Switch transducer leads at S1 & S2 |
| | Transducer failed as an open circuit | Replace transducer |
| Deadhead (Switch control) | Pump running against a closed discharge. | Make sure that there is not a valve closed or obstruction between the pump and pressure switch |
| | Damaged or clogged pressure switch | Check continuity across switch contacts without wire connected and replace and/or clean pressure port. |
| | Deadhead sensitivity incorrect | Adjust deadhead sensitivity in Underload Protection menu |
| Deadhead (Transducer Control) | Pump running against a closed discharge. | Make sure that there is not a valve closed or obstruction between the pump and pressure transducer |
| | Deadhead sensitivity incorrect | Adjust deadhead sensitivity in Underload Protection menu |
| | Clogged pressure transducer | Check transducer for pressure port and clean |
| | Damaged or inoperative transducer | Replace transducer |
| Low PSI (Transducer Control) | Pipe has not filled | Reset pipe fill mode in Menu #10 Control Settings and increase fill time if necessary. |
| | Valve closed between pump & transducer | Open valve between pump & transducer. |
| | Clogged Pressure transducer | Check transducer for pressure port & clean |
| | Damaged or inoperative transducer | Replace transducer |
| Dry Well | Over pumped/dry well | Wait for well to recover and automatic restart timer to time out |
| | Blocked pump screen | Clear pump screen |
| | Broken pump shaft | Replace pump shaft (or pump) |
| | Worn pump | Replace pump |
| Under Voltage | Low line voltage | Check line voltage Report low voltage to the power company |
| | Power was removed from Drive | Check voltage is present on all input lines & connections secure |
| (Color) Leg Open | Loose connection | Check connections on drive motor terminals for leg specified |
| | Defective splice | Check all splice connections on drop cable for leg specified |
| | Defective cable | Check continuity of drop cable for leg specified |
| | Open motor winding | Replace motor |
| Overheated | Excessive heating of Drive | Check that the ambient temperature is not above 125°F |
| | | Check for obstructed or inoperable fan |
| | | Check for blocked vents |
| Broken Pipe | Drive has been running without going into standby mode for set time | Check for broken or leaking pipe and repair as necessary |
| | Application calls for long run time | Increase broken pipe run time in Advanced Feature menu Turn off Broke Pipe protection in Advanced Feature menu |
| External Trip | Contacts closed on "Alarm In" terminals | Check condition of switch wired into "Alarm In" terminals |

SYSTEM TROUBLESHOOTING GUIDE

| SYMPTOM | POSSIBLE CAUSE | CORRECTIVE ACTION |
|--|---|--|
| Water flow rate is not as high as expected. | Motor/Pump is running backwards. | Switch two of the three wires leading from the controller to the 3-phase motor. |
| | Pump capacity cannot supply the demand. | Use pump with higher flow rating (if head requirement is still satisfied). |
| | Temperature in the controller is too high. If the controller's heat exchanger becomes too hot, the controller will reduce the output frequency to the motor to lower the power consumption. | Make sure there is at least 4 inches of room around the controller for movement of air. Avoid direct sunlight. Reduce ambient temperature below 104°F (40°C). Increase input voltage if below 230 VAC. |
| | Pump capacity cannot supply the demand. | Use pump with higher flow rating (if head requirement is still satisfied). |
| Excessive pressure fluctuations. | Waterlogged tank. | Check tank for bladder damage. Replace if necessary. Reset the tank pre-charge pressure (should be 70% of pressure switch/transducer setting). |
| | Pressure tank is too small for flow rating of the pump. | Use larger tank (4 gal. tank minimum). |
| Motor runs continuously with no flow demand. | Leak in the household or outdoor plumbing. | Check for leaky faucets, valves and/or pipe fittings and repair. |
| | Leak in the pitless adapter. | Re-seat the pitless adapter. Replace seal as needed. |
| Drive will not come out of standby mode | Bad pressure switch | Check continuity across pressure switch terminals and replace if necessary |
| | Loose pressure switch wire connection or broken wire | Check pressure switch wire connections on display board and at pressure switch. Check wire for continuity. |
| | Drive is in switch control mode and transducer is hooked up backwards. | Check to ensure transducer brown lead is connected to S1 and blue lead is connected to S2 terminals. Change control mode from switch to transducer. |

DRIVE SPECIFICATIONS

| | | TVS/VS15 | TVS/VS20 | TVS/VS30 | TVS50 |
|--|--------------------------------|---|----------------------------|-----------------------------|-----------------------------|
| Input from Power Source (single phase) | Voltage | 180 -264 AC | 180 -264 AC | 180 -264 AC | 180 -264 AC |
| | Frequency | 48 - 62 Hz | 48 - 62 Hz | 48 - 62 Hz | 48 - 62 Hz |
| | Current (max) | 14.5 Amps RMS 1ø | 19 Amps RMS 1ø | 23 Amps RMS 1ø | 36 Amps RMS 1ø |
| | Power Factor | 1.0 (constant) | 1.0 (constant) | 1.0 (constant) | 1.0 (constant) |
| Output to Motor (three-phase) | Voltage | Adjusts with Frequency | Adjusts with Frequency | Adjusts with Frequency | Adjusts with Frequency |
| | Frequency Range | 30 - 80 Hz | | | |
| | Current Factory Programmed | 5.9 amps (RMS, each phase) | 8.1 amps (RMS, each phase) | 10.9 amps (RMS, each phase) | 18.0 amps (RMS, each phase) |
| | Current (max) | 6.5 amps (RMS, each phase) | 8.5 amps (RMS, each phase) | 10.9 amps (RMS, each phase) | 18.0 amps (RMS, each phase) |
| Pressure Setting | Factory preset | 50 PSI | | | |
| | Adjustment range | 30 - 80 PSI switch / 15 - 95 PSI transducer | | | |
| Operating Conditions | Temperature (at 230 VAC input) | -20° to 50°C (-4° to 125°F) | | | |
| | Relative Humidity | Max 95% Non-condensing | | | |
| Controller Size | NEMA 3R (Indoor/Outdoor) | 17" H x 9.25" W x 5.25" D | | | 19" H X 9.75" W X 5.25" D |
| Weight | | 19 lbs. | | | 25 lbs. |
| Minimum generator sizing | | 4.8kW | 8.0kW | 10.0kW | 15.7kW |